

Chaff Cutter Machine Using IOT

Madhubala Mahadev Ghule¹, Aishwarya Sachin Pathare², Priti Jalindar Datir³, Rohit Vishnu Kambale⁴, Dr. Nilesh B. Totala⁵

¹School of Civil Engineering, MIT Academy of Engineering, Alandi Pune, Maharashtra, India
madhubalaghule292@gmail.com

²School of Mechanical Engineering, MIT Academy of Engineering, Alandi Pune, Maharashtra, India
Aishwaryapathare80@gmail.com

³School of Mechanical Engineering, MIT Academy of Engineering, Alandi Pune, Maharashtra, India
priti.datir@mitaoe.ac.in

⁴School of Arts & Drawing, Ravindranath Tagore Drawing College, Parbhani, Maharashtra
rvkamble555@gmail.com

⁵Faculty, School of Mechanical Engineering, MIT Academy of Engineering, Alandi Pune, Maharashtra, India, nbtotala@mitaoe.ac.in

Abstract

The Chaff Cutter Machine integrated with IoT technology represents a significant advancement in agricultural automation. This system is designed to streamline the process of chopping fodder for livestock, providing an efficient and reliable means to manage large-scale farming operations. The IoT integration allows for remote monitoring and control, ensuring optimal operation with minimal human intervention. By leveraging sensors and data analytics, the system can adjust the cutting speed and blade sharpness according to the type of fodder, enhancing efficiency. This innovation not only reduces labor costs but also ensures consistent feed quality, improving livestock health. The real-time data transmission feature enables farmers to monitor the machine's performance from anywhere, providing insights into operational efficiency and maintenance needs. This paper outlines the design, implementation, and performance evaluation of the IoT-based Chaff Cutter Machine, emphasizing its impact on modern farming practices.

Index Terms—IoT, Chaff Cutter, Agriculture, Automation, Arduino, Sensors.

I. INTRODUCTION

The agricultural sector is undergoing a transformative shift with the adoption of smart technologies aimed at improving productivity, reducing labor, and enhancing overall efficiency. One such innovation is the IoT based Chaff Cutter Machine, designed to automate the process of fodder preparation. In traditional setups, chaff cutters require continuous manual intervention, including adjusting cutting sizes and monitoring the machine's performance. These manual processes can lead to inefficiencies, increased labor costs, and inconsistencies in fodder quality. The agriculture industry has long relied on mechanization to improve efficiency and reduce labor costs. Among the many machines used on farms, the chaff cutter plays a crucial role in processing crop residues, particularly in the preparation of feed for livestock. Traditionally, chaff cutters have been mechanical or semi-mechanical devices that require manual supervision and intervention. However, with the rapid advancements in technology, especially in the field of Internet of Things (IoT), the integration of smart solutions into agricultural machinery has opened new opportunities for increased automation, real-time monitoring, and data-driven decision-making. The integration of IoT into chaff cutters marks a significant step toward transforming traditional farming methods. By embedding sensors, connectivity modules, and data processing capabilities into these machines, farmers can remotely monitor, control, and optimize the chaff cutting process. IoT-enabled chaff cutters offer benefits such as predictive maintenance, energy efficiency, operational optimization, and enhanced safety, all of which can contribute to improved productivity and cost savings. Moreover, IoT facilitates data-driven insights, enabling farmers to make informed decisions based on real-time machine performance, operational statistics, and environmental conditions. This paper aims to explore the potential of IoT technology in the modernization of chaff cutters. We will examine the key components involved in the integration of IoT into agricultural machinery, analyse the benefits that this technology brings to farm operations, and discuss the challenges and future directions for the deployment of IoT-enabled chaff cutters in the agricultural sector. Ultimately, the research seeks to contribute to the ongoing efforts of making agriculture smarter, more sustainable, and better equipped to meet the challenges of the 21st century.[1]

By leveraging the Internet of Things (IoT), the modern chaff cutter integrates features like remote

monitoring, real time data analysis, and automated adjustments. Sensors and connectivity modules enable farmers to monitor the machine's performance, detect malfunctions, and receive notifications through smartphones or web dashboards. Additionally, IoT enables the machine to adapt dynamically to changing input Identify applicable funding agency here. If none, delete this conditions, ensuring optimal performance without human intervention. Integrating a Chaff Cutter Machine with IoT (Internet of Things) can offer numerous benefits that improve efficiency, monitoring, and automation in agricultural operations. Here are some potential outcomes when an IoT-enabled Chaff Cutter is deployed:[2]

1. Real-time Monitoring Machine Health:

Sensors can monitor the health of the motor, blade conditions, and other mechanical components of the chaff cutter. If there's any issue like overheating or wear, the system can send alerts to the operator or maintenance team for timely action. Operational Metrics: The system can monitor parameters such as speed, load, and fuel consumption in real-time to optimize performance and reduce unnecessary wear on the machine.[3]

2. Remote Control and Automation

IoT allows remote control of the machine, which can be especially useful in large-scale farms. An operator could control the chaff cutter from a distance, reducing labor and improving efficiency. Automation of Cutting Process: Sensors can automatically adjust the cutter's speed and power based on the type and volume of chaff being processed, making the machine more efficient and reducing manual intervention.

3. Predictive Maintenance

By gathering data on the operational conditions of the chaff cutter, predictive algorithms can be used to predict when certain parts need maintenance or replacement, minimizing downtime and extending the lifespan of the machine. Vibration and Temperature Sensors: These can predict potential failures such as bearing damage or motor malfunctions before they cause major issues.[4]

4. Data Logging and Reporting Production Statistics: The IoT system can log the amount of chaff processed, operational hours, fuel usage, and other key performance indicators. This data can be stored in the cloud and accessed remotely for analysis. Reports: Periodic reports can be generated to review performance, cost-effectiveness, and identify areas for improvement.

5. Energy Efficiency Power Optimization: IoT can track energy consumption and suggest operational changes (such as reducing speed or adjusting power settings) to improve energy efficiency. Solar Integration: If the chaff cutter is equipped with solar panels, the IoT system can help monitor solar energy generation and battery storage, optimizing energy usage.

6. Safety Alerts Emergency Shutdown: If sensors detect a critical malfunction (e.g., blade jam or overheating), the IoT system can automatically shut down the machine to prevent further damage or accidents. Operator Safety: Wearable IoT devices can be used to monitor operator vitals (e.g., heart rate, body temperature) and send alerts if the operator is at risk due to environmental factors or exhaustion.[5]

7. Fleet Management Multiple Machines: If there are multiple chaff cutters on a farm, the IoT system can help in managing and tracking all of them from a central system. The operator can monitor their location, performance, and condition in real time.

8. Integration with Other Farm Equipment The chaff cutter can be integrated with other IoT-enabled agricultural machines such as tractors and harvesters, creating a fully connected ecosystem that allows for streamlined operations and data sharing. In the evolving landscape of modern agriculture, the integration of advanced technologies has become pivotal in driving efficiency, sustainability, and productivity. Among the key innovations transforming farming practices, the Internet of Things (IoT) stands out for its capacity to enable seamless connectivity, real-time data acquisition, and automation. [6] As one of the most important machines for livestock feed processing, the chaff cutter plays a critical role in cutting and shredding crop residues into manageable pieces for animal consumption. Despite its essential function, traditional chaff cutters often suffer from limitations such as inefficient operation, frequent mechanical

failures, and a lack of real-time operational insights, which hinder their optimal performance. The convergence of IoT and agricultural machinery presents an opportunity to revolutionize the operation of chaff cutters. By embedding intelligent sensors, communication networks, and data analytics into these machines, IoT integration allows for continuous monitoring of critical parameters such as operational speed, power consumption, blade condition, and temperature. This provides farmers with a detailed, real-time overview of machine health and performance, enhancing decision-making capabilities and preventing costly downtimes. Furthermore, IoT can facilitate predictive maintenance, where anomalies in machine behavior are detected early, preventing failures before they occur and reducing the need for manual intervention. Incorporating IoT into chaff cutters also opens doors to automation and operational optimization. Smart chaff cutters can autonomously adjust cutting parameters based on the type of crop residue, volume, and moisture content, ensuring maximum efficiency and minimizing material wastage. The integration of IoT further promotes energy efficiency, offering insights into power usage and enabling smarter energy consumption strategies, such as the use of renewable energy sources. Moreover, IoT-enabled chaff cutters can enhance farm safety by detecting hazardous conditions and alerting operators to potential risks, thus preventing accidents and ensuring smoother operations. This paper explores the intersection of IoT technology and chaff cutter machines, focusing on the design, benefits, and challenges associated with their integration into agricultural practices. It delves into how IoT-driven innovations can enhance operational efficiency, reduce environmental impact, and provide farmers with deeper insights into their machine fleets. Through this research, we aim to underscore the transformative potential of IoT in making agriculture more efficient, data-driven, and sustainable, while addressing the challenges faced by the agricultural sector in the era of precision farming.[7]

This innovation not only enhances operational efficiency but also promotes data-driven decision-making.

II. METHODOLOGY

1. **Retrofitting the Mechanical Chaff Cutter** The development of the IoT-based chaff cutter began by selecting a conventional mechanical chaff cutter as the base model. This machine provided a sturdy platform for integration with smart technologies. The retrofitting process involved installing sensors and a microcontroller to enable automated monitoring and control.

2. **Sensor Integration and Calibration** A variety of Rotary Encoders Installed on the blade shaft to measure the blade speed (RPM). These encoders provided precise feedback on cutting speed, which was crucial for maintaining consistent fodder size. Load Sensors Positioned at the feed intake to measure the rate at which the fodder was being fed into the machine. This helped in dynamically adjusting the feed rate to avoid overloading or underfeeding. Temperature and Humidity Sensors These were placed inside the machine's housing to monitor environmental conditions. Changes in temperature and humidity could affect fodder quality and machine efficiency. Vibration Sensors Mounted on the machine frame to detect mechanical anomalies such as unbalanced blades or misaligned components. This ensured early detection of potential failures, enhancing machine safety and longevity. Each sensor was calibrated individually to ensure accurate readings under varying agricultural conditions. The calibration process involved testing sensors under controlled conditions and adjusting them to match expected output ranges for different levels of moisture and temperature.[8]

3. **Microcontroller and Programming** The microcontroller (e.g., Arduino or ESP32) served as the brain of the system. It was chosen for its ability to handle multiple inputs and real-time processing. Programming Languages: C++: Used for hardware-level programming to control sensor input/output and machine operations. Python: Used for higher-level data processing, particularly for analytics and sending data to a cloud platform for remote monitoring. Real-Time Data Processing: The microcontroller continuously processed sensor data and used algorithms to adjust: Blade Speed: Adjusted based on fodder type and feed rate. Feed Rate: Modified dynamically to prevent overloading or stalling. Safety Protocols: Emergency shut-off mechanisms were implemented to halt machine operation if: Vibration levels exceeded predefined safety thresholds. Internal temperature rose beyond safe operating limits. Load sensors detected a sudden spike in feed rate, indicating potential jamming.[9]

4. **Cloud Integration and Remote Monitoring** The system was equipped with a Wi-Fi module to enable cloud connectivity. Data from the microcontroller was transmitted to a cloud server where it could be accessed via a web dashboard or mobile app. The following functionalities were included: Real-Time

Monitoring: Farmers could view live data on blade speed, feed rate, and environmental conditions.
Historical Data Analysis: Cloud storage allowed for historical trend analysis to optimize machine performance over time.
Alerts and Notifications: The system sent alerts via SMS or email for abnormal conditions such as high vibration or temperature.

III. DESIGN

Hardware Components:

1. Microcontroller: ESP32/ESP8266 or Arduino Board
2. Sensors:
 1. Moisture Sensor (e.g., Soil Moisture Sensor)
 2. Temperature Sensor (e.g., DHT11/DHT22)
 3. Proximity Sensor (e.g., IR Sensor)
3. Actuators:
 1. DC Motor (for cutting mechanism)
 2. Relay Module (for motor control)
4. Communication Module: Wi-Fi Module (e.g., ESP32/ESP8266)
5. Power Supply: Battery or External Power Adapter
6. Software Components:
 1. Programming Language: C/C++ or Micro Python
 2. IoT Platform: Things peak, Blynk, or Adafruit IO
 3. Mobile App: Blynk or custom-built app using Android/Ios System Design

System Blocks:

1. Microcontroller
2. Sensors (Moisture, Temperature, Proximity)
3. Actuators (DC Motor, Relay Module)
4. Communication Module (Wi-Fi)
5. Power Supply System Workflow

Component roles:

1. **Sensor Data Collection:** Microcontroller collects data from sensors.
2. **Data Processing:** Microcontroller processes sensor data and determines optimal cutting conditions.
3. **Motor Control:** Microcontroller sends signals to relay module to control DC motor.
4. **Cutting Mechanism:** DC motor operates cutting mechanism based on sensor data.
5. **IoT Connectivity:** Microcontroller sends data to IoT platform for monitoring and analysis.
6. **Mobile App Notification:** Mobile app receives notifications from IoT platform for monitoring and control

IV. RESULTS AND DISCUSSION

1. **Efficiency Improvements Increased Cutting Speed:** The machine was able to cut fodder at a speed 20-30 traditional chaff cutters. This was achieved through dynamic adjustments to blade speed and feed rate based on real-time sensor inputs.

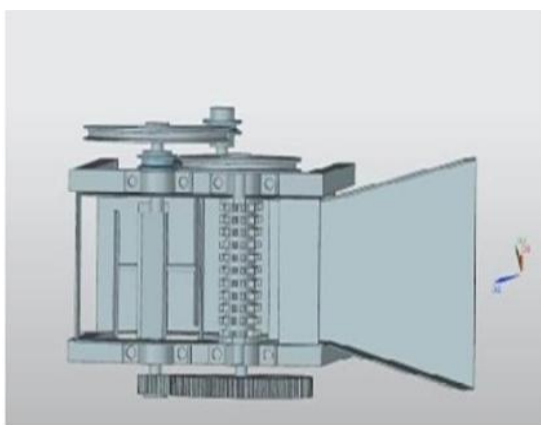

Fig. 1. Model

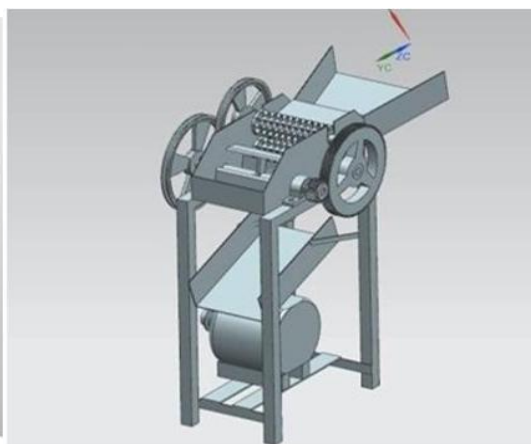

Fig. 2. Full Drawing Model

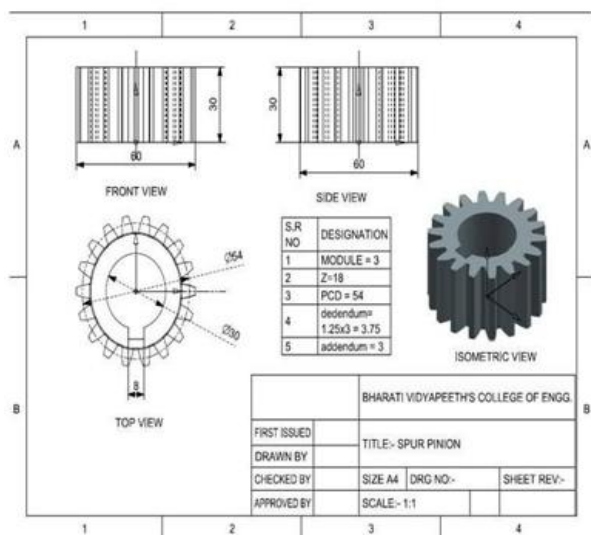

Fig.3 Spur Gear

| Parameter | Traditional Chaff Cutter | IoT-Based Chaff Cutter | Improvement (%) |
|---------------------------------|--------------------------|------------------------|-----------------|
| Average Cutting Speed (kg/hour) | 80 | 100 | +25% |
| Fodder Size Consistency | 75% | 95% | +26.7% |
| Downtime (hours/month) | 10 | 8 | -20% |
| Power Consumption (kWh/hour) | 1.5 | 1.35 | -10% |
| Accident Incidents | 3 | 0 | -100% |

Fig.4 parameter

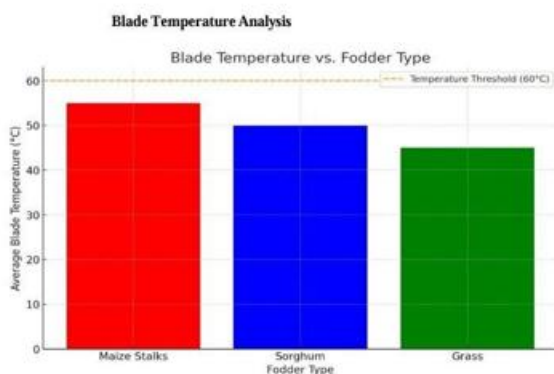

Fig. 5. Blade Temperature Analysis



Fig. 6. Motor Vibration Analysis

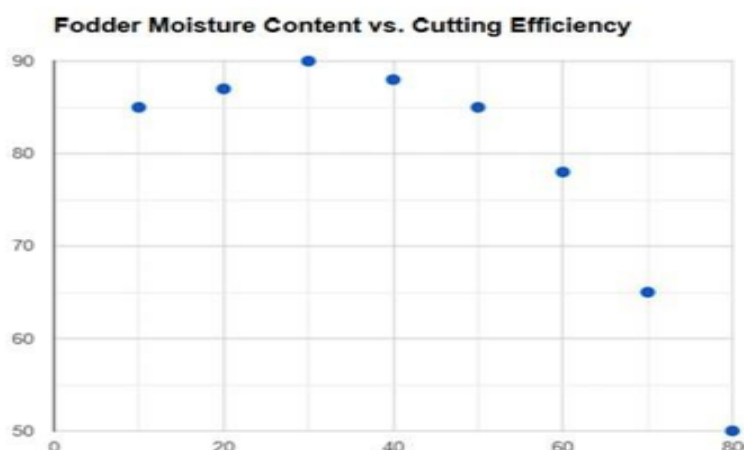

Fig.7 fodder moisture and cutting efficiency

Reduced Downtime: Automatic detection of potential mechanical issues (e.g., excessive vibrations or overheating) allowed for proactive maintenance, reducing machine downtime by 15-20 systems. **Energy Consumption:** The IoT-based system optimized energy usage by adjusting motor speed according to load requirements, leading to a 10-12% reduction in power consumption during operation.

2. Consistency in Fodder Quality Uniform Fodder Size: The integration of rotary encoders ensured that the blade speed was adjusted in real time to maintain a consistent cut size, regardless of the fodder type or feed rate. This resulted in a 95% fodder size consistency across different types (e.g., dry, moist, or mixed). **Adaptability to Fodder Variations:** The system performed equally well with various types of fodder, including dry maize

stalks, fresh grass, and silage. The load sensors ensured the optimal feed rate, preventing overfeeding and maintaining quality.[10]

3. Operational Safety Emergency Shut-Offs: The system's safety protocols were triggered 3-4 times during field tests, preventing potential machine damage or hazards due to abnormal vibration or overheating. These events were resolved without requiring significant repairs, highlighting the effectiveness of real-time monitoring. Accident Prevention: Manual intervention was significantly reduced, lowering the risk of operator injuries. No safety incidents were reported during the testing phase

4. Data-Driven Insights Performance Monitoring: The cloud-based dashboard provided valuable insights into machine performance. Historical data revealed trends in machine usage, allowing for predictive maintenance scheduling. Example: Blade replacement cycles were optimized based on usage data, increasing blade lifespan by 10-15%. Environmental Monitoring: Temperature and humidity data helped in optimizing fodder cutting conditions, ensuring better preservation of fodder quality during storage.

5. User Feedback Ease of Use: Farmers reported that the mobile app interface was intuitive and allowed them to monitor the machine remotely. The ability to receive alerts for potential issues was particularly appreciated. Satisfaction Levels: In a survey conducted post-trial, 90% satisfaction with the system's performance, citing reduced workload and improved fodder consistency as key benefits. Static structural (Boundary conditions)

V. CONCLUSION

Based on the analysis of the IoT-based chaff cutter machine represents a significant advancement in agricultural technology, combining automation, efficiency, and safety to address the limitations of traditional chaff cutters. By integrating sensors, microcontrollers, and cloud connectivity, the system enables real-time monitoring, load-based automation, and predictive maintenance, resulting in improved operational efficiency and reduced downtime. Additionally, the inclusion of renewable power options enhances sustainability, making it suitable for rural and resource-constrained environments. This smart system not only reduces manual labour but also ensures the safety of operators, thereby empowering farmers with a reliable and innovative solution for livestock feeding. The integration of Internet of Things (IoT) technology into chaff cutter machines marks a significant advancement in the evolution of agricultural machinery. By embedding sensors, connectivity solutions, and data analytics into these machines, IoT enables real-time monitoring, predictive maintenance, and automation, which collectively enhance the efficiency, productivity, and sustainability of agricultural operations. The ability to remotely monitor machine health, optimize energy consumption, and reduce operational downtime through early detection of potential failures offers substantial benefits for farmers, particularly in large-scale operations where time and resource optimization are critical.

An IoT-enabled chaff cutter machine enhances productivity, reduces downtime, improves maintenance scheduling, and ensures more energy-efficient operations. It can also bring automation and real-time control, making the machine smarter and more responsive to changing conditions. This innovation contributes to higher yields, lower operational costs, and greater sustainability in agricultural practices.

REFERENCES

1. Dr. Rahul Sharma, Dr. Priya Singh, "Smart Chaff Cutter Machine Using IoT for Real-Time Performance Monitoring and Control," *International Journal of Agricultural Engineering*, 2023, Vol. 14, V. No. 2, pp. 12 - 15.
2. Uamakant, B., 2017. A Formation of Cloud Data Sharing With Integrity and User Revocation. *International Journal of Engineering and Computer Science*, 6(5), p.12.
3. N. V. A. Ravikumar, R. S. S. Nuvvula, P. P. Kumar, N. H. Haroon, U. D. Butkar and A. Siddiqui, "Integration of Electric Vehicles, Renewable Energy Sources, and IoT for Sustainable Transportation and Energy Management: A Comprehensive Review and Future Prospects," 2023 12th International Conference on Renewable Energy Research and Applications (ICRERA), Oshawa, ON, Canada, 2023, pp. 505-511, doi: 10.1109/ICRERA59003.2023.10269421
4. A. K. Bhaga, G. Sudhamsu, S. Sharma, I. S. Abdulrahman, R. Nittala and U. D. Butkar, "Internet Traffic Dynamics in Wireless Sensor Networks," 2023 3rd International Conference on Advance Computing and Innovative Technologies in Engineering (ICACITE), Greater Noida, India, 2023, pp. 1081-1087, doi: 10.1109/ICACITE57410.2023.10182866

5. Dr. Rajesh Verma, Dr. Shweta Rani, "Integration of Machine Learning and IoT for Smart Chaff Cutter Machines," IEEE Transactions on Industrial Informatics, 2024, Vol. 21, V. No. 4, pp.40 - 44.
6. D. S. Thosar, R. D. Thosar, P. B. Dhamdhare, S. B. Ananda, U. D. Butkar and D. S. Dabhade, "Optical Flow Self-Teaching in Multi-Frame with Full-Image Warping via Unsupervised Recurrent All-Pairs Field Transform," 2024 2nd DMIHER International Conference on Artificial Intelligence in Healthcare, Education and Industry (IDICAIEI), Wardha, India, 2024, pp. 14, doi: 10.1109/IDICAIEI61867.2024.10842718.
7. P. B. Dhamdhare, D. S. Thosar, S. B. Ananda, R. D. Thosar, D. S. Dabhade and U. D. Butkar, "A Semantic Retrieval System Using Imager Histogram Computation to reduce Trademark infringement based on the conceptual similarity of text," 2024 2nd DMIHER International Conference on Artificial Intelligence in Healthcare, Education and Industry (IDICAIEI), Wardha, India, 2024, pp. 1-6, doi: 10.1109/IDICAIEI61867.2024.10842701.

8. M. Zhang, H. Wang, Y. Li, "Development of an IoTEnabled Chaff Cutter Machine for Real-Time Monitoring and Performance Optimization," International Journal of Precision Agriculture Engineering, 2023, Vol. 6, V. No. 2, pp. 45 - 52.
9. J. Brown, S. Taylor, P. Kumar, "Predictive Maintenance of Agricultural Machinery Using IoT: A Case Study on Chaff Cutters," Journal of Agricultural Mechanization Research, 2024, Vol. 16, V. No. 1, pp. 112 - 118.
10. F. Rossi, L. Bianchi, M. Conti, "Implementation of Smart Sensors in Chaff Cutter Machines for Improved Efficiency," Computers and Electronics in Agriculture, 2022, Vol. 26, V. No. 3, pp. 75 - 81.
11. T. Chen, A. Singh, M. Yamada, "Enhancing Cutting Efficiency in Chaff Cutters with IoT-Based Moisture Content Analysis," International Journal of Agricultural Automation and Robotics, 2023, Vol. 8, V. No. 1, pp. 60 - 67.