

Photoactive CuO-TiO₂ Composites for Dye Degradation Under Visible Light

Dipti Rani, L. P. Purohit, Himanshu Gupta¹

¹Department of Physics, Gurukula Kangri (Deemed to be University), Haridwar 249 404, Uttarakhand, India

*Corresponding author: himanshu.gupta@gkv.ac.in

Abstract

This study demonstrates the enhanced photocatalytic efficacy of CuO-TiO₂ composites for large-scale applications in the remediation of water contaminants. CuO-TiO₂ composites were synthesized by sol-gel precipitating method with 1:2 volume ratio and examined the photocatalytic activity of synthesized nanomaterials. XRD patterns showed tenorite and anatase phases for CuO and TiO₂ respectively, however a mixed structure was observed for CuO-TiO₂. The optical bandgaps were found between 1.7 and 3.25 eV for the CuO, TiO₂ and CuO-TiO₂. The CuO-TiO₂ (1:2) was found suitable for the degradation of methyl blue (MB) dye under irradiation. The low recombination rates and boosted charge separation were accountable to improve the performance of the photocatalytic activity in visible light. The photodegradation was improved substantially from CuO to CuO-TiO₂ (1:2) for MB dye.

Keywords: Photocatalytic application, dye degradation, XRD

INTRODUCTION

In recent years, there has been growing research towards removing the air and water pollutants from the environment, with heterogeneous photocatalysis evolving as a prominent area of research. Among various treatment approaches, The oxidation process is one of the emergent process used to eliminate the organic contaminants from dyes because of its fast degradation, better stability, environment friendly and low cost [1]. These processes employ semiconductor-based photocatalysts to break down organic dyes and other contaminants.

Semiconductor nanomaterials are especially appreciated for their consistent performance in photocatalytic applications. semiconductor based photocatalysts like TiO₂, ZnO, CdO, WO₃, and MoO₃ have revealed substantial effectiveness in degrading organic dyes [2]. Whereas, TiO₂ in particular, has gained widespread popularity due to its high photo-stability, non-toxicity, and strong activity compared to dyes such as methylene blue (MB) and methyl orange (MO) [3]. However, TiO₂'s comparatively large band gap (3.2 eV) prohibits its activity to ultraviolet light, which signifies a small fraction of solar energy. Furthermore, the rapid recombination of charge carriers restricts its practical catalytic efficiency [4].

To address these challenges, researchers have explored various methods to enhance photocatalytic performance, such as creating nanocomposite semiconductors that respond to visible light and coupling different semiconducting materials [5] such as ZnO-CdO [6], TiO₂-MgO [7], CdO-TiO₂[8], and ZnO-MgO [9] etc. These combinations can improve charge separation via heterojunction formation, allowing for more effective electron and hole transfer when exposed to light. As a result, the overall degradation efficiency of organic pollutants is increased through optimized interactions within these advanced catalysts.

Copper oxide (CuO) is a very capable semiconductor material due to having a bandgap varying from 1.2 to 1.5 eV. CuO under irradiation can stimulate the separation of electron-hole pairs [10]. Its advantageous traits comprise strong electrical conductivity, prominent chemical stability, and higher carrier concentrations causing from oxygen vacancies in interstitial sites. These features contribute to higher electron mobility, and hence, increases the CuO suitability for photocatalytic applications. Moreover, when CuO is paired with TiO₂ i.e. CuO-TiO₂ composites, some additional oxygen vacancies can be introduced [11]. This combination endorses improved separation of electron-hole pairs and enhancements the photodegradation process under visible light conditions.

In one of the studies, Huang et al. examined the photocatalytic outcome of CuO & TiO₂ junction for the H₂ production [12]. Gray et al. studied the consequence of substitutional Cu²⁺ sites and confirmed that Cu²⁺ sites improved the photocatalytic activity of CuO-TiO₂ nanocomposite [13]. Moreover, Fornasiero et al. exhibited that CuO_x and TiO₂ along with Cu-CuO_x species dispersion can significantly augment the catalytic properties [14]. CuO-TiO₂ photocatalysts are particularly efficient because they enable effective separation of photo-generated electron-hole pairs, which considerably enriches photocatalytic activity. Incorporating materials with different bandgaps such as CuO-TiO₂ helps suppress

the recombination of these charge carriers under irradiation, enabling the degradation of organic pollutants. Research by Khan et al. [15] highlighted that the coupling of two distinct semiconductors improves photocatalytic performance under visible-light irradiation.

In present research work, CuO, TiO₂ and CuO-TiO₂ photocatalyst with (1:2) volume ratios were synthesized using the sol-gel precipitation method. The optical characteristics, surface morphology, and dye degradation behavior of the materials were thoroughly analyzed. To the best of the authors' knowledge, CuO-TiO₂ nanomaterials synthesized via the sol-gel method has not been extensively investigated for their photocatalytic applications. This unique single-step sol-gel approach enables the formation of CuO-TiO₂ composites with improved physicochemical properties, making it a promising technique for producing highly efficient photocatalysts without the need for additives. The resulting materials exhibit a combination of CuO and anatase-phase TiO₂ with reduced band gap energy, which enhances their visible light absorption and photocatalytic efficiency.

2. Experimental Work

Cuprous acetate dehydrate, titanium isopropoxide, hydrochloric acid, sodium hydroxide (NaOH), 2-methoxyethanol, double-distilled water and methanol were employed as starting materials for synthesizing CuO-TiO₂ composites via the sol-gel precipitation technique. Two separate precursor solutions, each with a concentration of 0.5 M, were prepared. For the CuO solution, 13.32 grams of Cuprous acetate dihydrate was dissolved in 100 mL of double-distilled water. For the TiO₂ solution, 14.21 mL of titanium isopropoxide was mixed with 100 mL of 2-methoxyethanol. Both solutions were uninterruptedly stirred for 5 hours at room temperature until clear, particle-free sols were achieved. This well-controlled sol-gel process confirms homogeneous mixing at the molecular level, which is vital for the formation uniform CuO-TiO₂ composites with desirable photocatalytic properties.

CuO-TiO₂ solutions were prepared with volume ratio of 1:2 by adding different quantity of CuO and TiO₂. The mixtures were stirred continuously for an additional 3 hours at room temperature to ensure thorough blending of the semiconductors. After an aging period of 24 hours, sodium hydroxide (NaOH) solution was added dropwise to each precursor mixture to induce precipitation. The suspensions were then heated at 80 °C for 35 minutes to complete the chemical reactions. The resulting particles were separated by centrifugation and subsequently annealed at 450 °C for 6 hours.

The synthesized CuO-TiO₂ nanoparticles were characterized by various techniques. X-ray diffraction (XRD) measurements were performed using a Bruker D8 Advance instrument to examine the crystal structure. Surface morphology was examined via field emission scanning electron microscopy (FE-SEM) using a Zeiss Ultra-60 microscope, and phase analysis was conducted with a JEOL-2100F Cryo-high-resolution transmission electron microscope (HR-TEM). Optical properties were assessed using a Shimadzu 3600 UV-Vis-NIR spectrophotometer.

2.1 Photocatalyst properties

To assess the photocatalytic degradation performance for methylene blue (MB), experiments were carried out in a 100 mL borosilicate glass reactor exposed to a 200 W tungsten lamp positioned 4 cm above the sample. The dye solutions were prepared at a concentration of 10 mg/L, with 5 g/L of the catalyst thoroughly suspended for optimal contact. Throughout the experiments, the pH was adjusted and maintained at 7 using either hydrochloric acid or sodium hydroxide, as neutral pH conditions have been shown to maximize dye removal based on the surface charge dynamics of the photocatalysts. Previous studies confirm that pH 7 provides ideal conditions for photodegradation [16–18].

Prior to irradiation, the catalyst-dye mixtures were treated with ultrasound for 10 minutes to disperse impurities and ensure homogeneous mixing. The resulting supernatants were analysed for MB concentrations at their respective maximum absorption wavelengths using a Shimadzu 3600 UV-Vis-NIR spectrophotometer.

3. RESULTS AND DISCUSSIONS

3.1. X-ray diffraction (XRD)

X-ray diffraction (XRD) analysis of CuO, TiO₂ and CuO-TiO₂ composite samples reveals distinct crystalline phases. The pure CuO sample displays three sharp peaks at diffraction angles (2 θ) of approximately 35.5°, 38.9°, and 48.8°, consistent with monoclinic CuO and matching standard values from JCPDS card 41-0254. The TiO₂ sample exhibits peaks at 25.5°, 38.0°, 48.1°, 54.0°, and 55.3°, confirming the presence of anatase-phase TiO₂ (JCPDS 01-073-1764), which is widely recognized in photocatalytic applications.

For the CuO-TiO₂ composite, the diffraction pattern demonstrates peaks corresponding to both CuO and TiO₂, with features similar to the individual parent oxides. The predominance of CuO signals indicates a strong presence of copper oxide in the composite, and no extraneous peaks or significant peak shifts were detected, suggesting high purity and stable crystalline phases without the formation of secondary products or phase transformations. The absence of spurious peaks further validates the successful synthesis of the binary composite material.

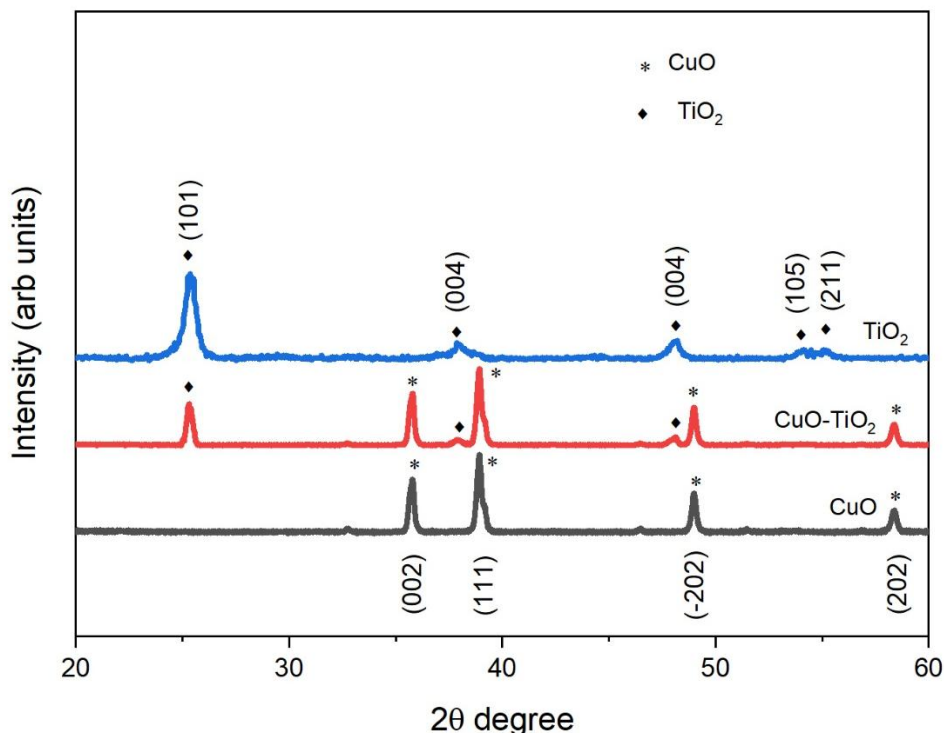

Fig.1 XRD analysis of CuO, TiO₂ and CuO-TiO₂ composites.

3.2 Surface morphological analysis

FE-SEM images were used to identify the surface morphology of the CuO-TiO₂ composites. Fig. 2(a-c) depict the SEM images of samples CuO, TiO₂ and CuO-TiO₂, respectively. Fig 2(a) illustrates that CuO nanoparticles tend to aggregate, forming clusters of particles with irregular shapes. In contrast, Fig 2(c) reveals that most TiO₂ nanoparticles are smaller and predominantly oval-shaped, distinguishing them from the larger CuO particles. Fig 2(b) displays a mixture of these two types, with the larger CuO particles and smaller TiO₂ particles appearing together, indicative of the mixed or coupled semiconductor structure characteristic of the composite material.

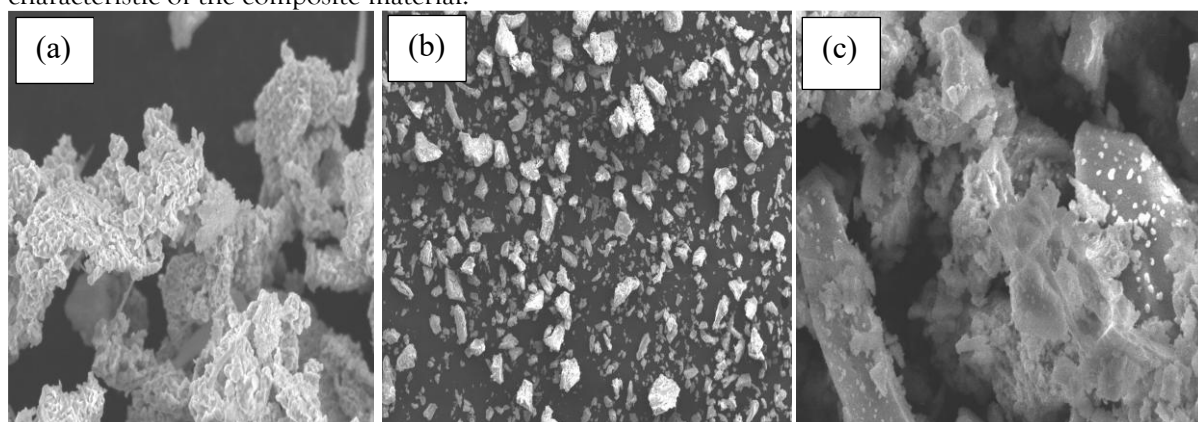

Fig 2(a-c) FESEM Images at 5μm (a) Pure CuO (b) Pure TiO₂ and (c) CuO-TiO₂

3.3 UV-vis analysis

The optical properties of CuO-TiO₂ composites were evaluated using a UV-Vis spectrophotometer, capturing reflectance spectra in the 200–800 nm range to estimate the band gap under ambient conditions. With increasing TiO₂ content, a blue shift in the absorption edge of CuO was observed, indicating that quantum confinement effects became more prominent. The optical band gap energies of CuO-TiO₂ material was calculated by Tauc's relation as mentioned in Eq. (1)

$$\alpha h\nu = (h\nu - E_g)^n \quad (1)$$

Band gap energies for the CuO-TiO₂ composites were determined using Tauc's relation, plotting n denotes the type of transition (0.5 for direct, 2 for indirect band gap). Sample CuO-TiO₂ absorbed visible light and exhibited a blue shift, showing that increasing TiO₂ slightly raised the band gap due to lattice mismatch and changes in particle size [19]. These observations suggest effective visible-light harvesting, possibly due to structural defects and oxygen vacancies induced during synthesis [20].

3.4 Photocatalytic activity

All samples were analysed for photo-degradation of MB dyes to evaluate the behaviour of CuO-TiO₂ composites. Eq. (2) used to measure the photo-degradation efficiency.

$$\% \text{ Photo-degradation} = \frac{C_0 - C_t}{C_0} \times 100 \quad (2)$$

where, C₀ and C_t denotes the concentration at time t= 0 and T= t min.

Among the synthesized samples, CuO-TiO₂ exhibited the highest photocatalytic efficiency for degrading MB dye under visible light. The absorption spectra of MB dye recorded during different reaction times clearly demonstrate significant degradation. The reaction duration was fixed at 60 minutes for all samples, which to the best of current knowledge, represents one of the shortest times reported for such high-efficiency photocatalysis.

The coupling of CuO and TiO₂ semiconductors improves charge carrier separation, thus enhancing dye degradation. In contrast, the pure phases suffer from rapid recombination of photogenerated electrons and holes, undermining their photocatalytic effectiveness. Mechanistically, upon visible light irradiation, electron-hole pairs form as electrons transition from the valence band to the conduction band of the catalyst. Some recombine, but many participate in redox reactions, generating reactive oxygen species including hydroxyl radicals ($\cdot\text{OH}$) and superoxide anions ($\cdot\text{O}^2$) that mineralize the dyes. The conduction band of CuO lies at a lower energy than TiO₂, facilitating electron transfer from CuO to TiO₂. Anatase TiO₂, known for suppressing electron-hole recombination, enhances this charge separation process, leading to improved photocatalytic activity.

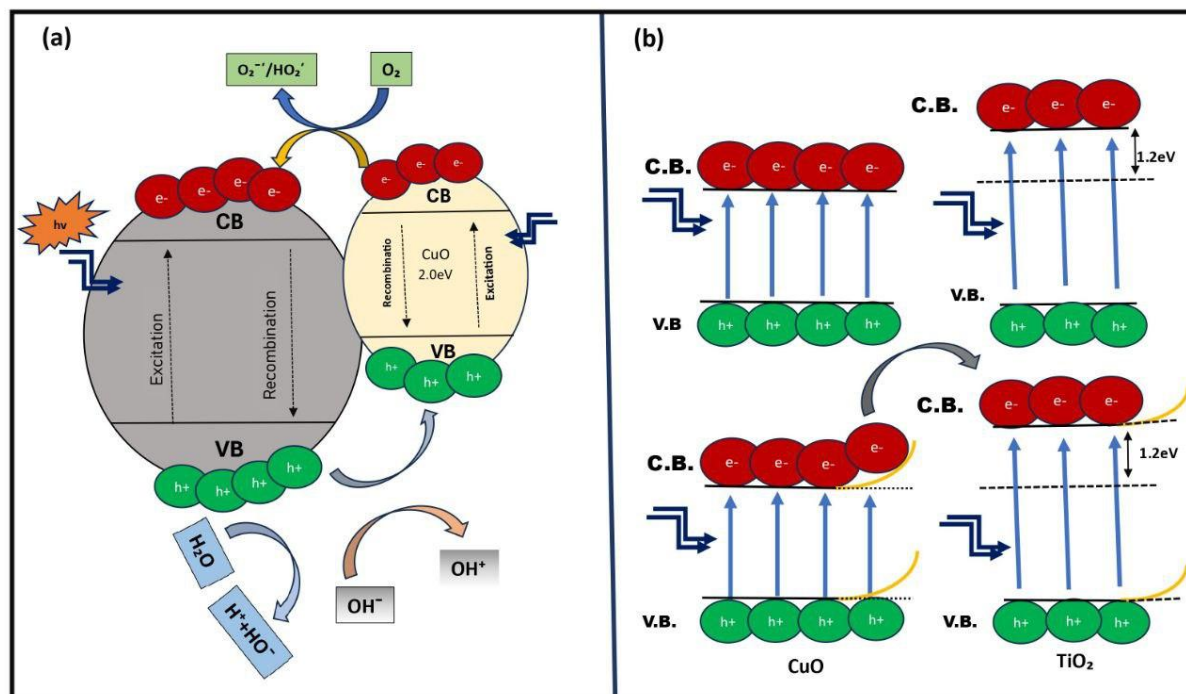

Fig. 6. (a) Photo-degradation of MB dye and (b) band position of CuO and TiO₂.

Overall, the CuO-TiO₂ composite demonstrates optimum visible-light photocatalytic degradation performance, excellent stability, and a favorable mechanism for effective dye mineralization in aqueous solutions. The photocatalytic performance of CuO, TiO₂ and CuO-TiO₂ with a reaction time of 60 min is comes out to be 54.95 %, 76.10 % and 92.25 % respectively. The previous work reported by different researchers using different dye is mentioned table 1.

Table 1

Composite	Dye	Time (min)	Efficiency (%)	Reference
-----------	-----	------------	----------------	-----------

CuO-TiO ₂	Rh-B	120	97	[21]
CuO-TiO ₂	MO	210	89	[22]
CuO-TiO ₂	Rh-B	360	65	[23]
CuO-TiO ₂	MB	60	95	Present Work

4. CONCLUSION

Photocatalytic treatment is a crucial technique for degrading pollutants in water. In the current study, CuO-TiO₂ composites were synthesized using the sol-gel precipitation method and employed for photocatalytic degradation of MB dye under visible light. In CuO-TiO₂ sample, the TiO₂ concentration caused a blue shift in the CuO absorption band edge and hence, raised the optical band gap energy from 2.3 eV to 3.6 eV. The CuO-TiO₂ nanocomposite exhibited superior photocatalytic efficiency for MB degradation compared to its individual components, achieving faster reaction times under visible irradiation. This enhanced photocatalytic performance highlights the potential for using CuO-TiO₂ composites in large-scale commercial water treatment applications. The composite's improved light absorption, charge separation, and surface properties contribute to its effectiveness in decomposing organic contaminants present in wastewater.

REFERENCES

- [1] Saray A M, Yousefi R, Zare-Dehnavi N and Jamali-Sheini F 2019 Improvement visible-light photocatalytic performance of single-crystalline SnSe_{1-x} NPs toward degradation of organic pollutants *Solid State Sci.* **98** 106044
- [2] Liao M, Wu L, Zhang Q, Dai J and Yao W 2019 Controlled Morphology of Single-Crystal Molybdenum Trioxide Nanobelts for Photocatalysis *J. Nanosci. Nanotechnol.* **20** 1917-21
- [3] Zhang J, Xu L J, Zhu Z Q and Liu Q J 2015 Synthesis and properties of (Yb, N)-TiO₂ photocatalyst for degradation of methylene blue (MB) under visible light irradiation *Mater. Res. Bull.* **70** 358-64
- [4] Upadhyay G K, Rajput J K, Pathak T K, Pal P K and Purohit L P 2020 Tailoring and optimization of hybrid ZnO : TiO₂ : CdO nanomaterials for advance oxidation process under visible light *Appl. Surf. Sci.* **509** 145326
- [5] Meng A, Zhang L, Cheng B and Yu J 2019 Dual Cocatalysts in TiO₂ Photocatalysis *Adv. Mater.* **31** 1-31
- [6] Pathak T K, Rajput J K, Kumar V, Purohit L P, Swart H C and Kroon R E 2017 Transparent conducting ZnO-CdO mixed oxide thin films grown by the sol-gel method *J. Colloid Interface Sci.* **487** 378-87
- [7] Bandara J, Kuruppu S S and Pradeep U W 2006 The promoting effect of MgO layer in sensitized photodegradation of colorants on TiO₂/MgO composite oxide *Colloids Surfaces A Physicochem. Eng. Asp.* **276** 197-202
- [8] Upadhyay G K, Rajput J K, Pathak T K, Swart H C and Purohit L P 2020 Photoactive CdO:TiO₂ composites for dyes degradation under visible light *Mater. Chem. Phys.* **253** 123191
- [9] Rana V S, Rajput J K, Pathak T K and Purohit L P 2018 Multilayer MgZnO/ZnO thin films for UV photodetectors *J. Alloys Compd.* **764** 724-9
- [10] Tuerdi A, Abdukayum A and Chen P 2017 Synthesis of composite photocatalyst based on the ordered mesoporous carbon-CuO with high photocatalytic activity *Mater. Lett.* **209** 235-9
- [11] Sahu K, Bisht A, Kuriakose S and Mohapatra S 2020 Two-dimensional CuO-ZnO nanohybrids with enhanced photocatalytic performance for removal of pollutants *J. Phys. Chem. Solids* **137** 109223
- [12] Wang Z, Liu Y, Martin D J, Wang W, Tang J and Huang W 2013 CuOx-TiO₂ junction: What is the active component for photocatalytic H₂ production *Phys. Chem. Chem. Phys.* **15** 14956-60
- [13] Li G, Dimitrijevic N M, Chen L, Rajh T and Gray K A 2008 Role of Surface / Interfacial Cu²⁺ Sites in the Photocatalytic Activity of Coupled CuO - TiO₂ Composites *J. Phys. Chem. C* **112** 19040-4
- [14] Gombac V, Sordelli L, Montini T, Delgado J J, Adamski A, Adami G, Cargnello M, Bernai S and Fornasiero P 2010 CuOx-TiO₂ Photocatalysts for H₂ production from ethanol and glycerol solutions *J. Phys. Chem. A* **114** 3916-25
- [15] Khan M E, Khan M M and Cho M H 2017 Ce³⁺-ion, Surface Oxygen Vacancy, and Visible Light-induced Photocatalytic Dye Degradation and Photocapacitive Performance of CeO₂-Graphene Nanostructures *Sci. Rep.* **7** 1-17
- [16] Yan X, Xue C, Yang B and Yang G 2017 Novel three-dimensionally ordered macroporous Fe³⁺-doped TiO₂ photocatalysts for H₂ production and degradation applications *Appl. Surf. Sci.* **394** 248-57
- [17] Tahir M, Tahir B and Amin N A S 2017 Synergistic effect in plasmonic Au/Ag alloy NPs co-coated TiO₂ NWs toward visible-light enhanced CO₂ photoreduction to fuels *Appl. Catal. B Environ.* **204** 548-60
- [18] Upadhyay G K, Rajput J K, Pathak T K, Kumar V and Purohit L P 2019 Synthesis of ZnO : TiO₂ composites for photocatalyst application in visible light *Vacuum* **160** 154-63
- [19] Naskar M K, Patra A and Chatterjee M 2006 Understanding the role of surfactants on the preparation of ZnS nanocrystals *J. Colloid Interface Sci.* **297** 271-5
- [20] Peymanfar R and Ramezanalizadeh H 2018 Sol-gel assisted synthesis of CuCr₂O₄ nanoparticles: An efficient visible-light driven photocatalyst for the degradation of water pollutions *Optik (Stuttg)*. **169** 424-31
- [21] Kavitha V, Ramesh P S and Geetha D 2016 Synthesis of Cu loaded TiO₂ nanoparticles for the improved photocatalytic degradation of Rhodamine B *Int. J. Nanosci.* **15** 1-8
- [22] Koohestani H and Khatiboleslam S 2016 Photocatalytic degradation of methyl orange and cyanide by using TiO₂ / CuO composite *Desalin. Water Treat.* **57** 22029-38
- [23] Leong C Y, Teh H L, Chen M C and Lee S L 2022 Effect of Synthesis Methods on Properties of Copper Oxide Doped Titanium Dioxide Photocatalyst in Dye Photodegradation of Rhodamine B *Sci. Technol. Indones.* **7** 91-7