

# Alternative Fuel Potential of Acetylene: Environmental Investigations of Working Characteristics in SI Engine

Moorthi V<sup>1</sup>, Ravi G<sup>2</sup>, Jose Ananth Vino V<sup>3\*</sup>, Kumaravel P<sup>4</sup>, Nallappan R<sup>5</sup>, Nagendiran B<sup>5</sup>,

<sup>1</sup>Department of Mechanical Engineering, Annapoorana Engineering College (Autonomous), Salem, 636308, Tamil Nadu, India.

<sup>2</sup>Department of Mechanical Engineering, Sri Sai Ram Engineering College, Chennai, 600045, Tamil Nadu, India.

<sup>3</sup>Department of Mechanical Engineering, Bharath Institute of Higher Education and Research, Chennai, 600073, Tamil Nadu, India.

<sup>4</sup>Department of Mechanical Engineering, Sona College of Technology, Salem, 636005, Tamil Nadu, India.

<sup>5</sup>Department of Mechanical Engineering, AVS College of Technology, Salem, 636106, Tamil Nadu, India.

<sup>3\*</sup>Corresponding author: [ananthvinovj258@gmail.com](mailto:ananthvinovj258@gmail.com)

---

## Abstract

The increasing demand for energy and the environmental concerns associated with conventional fossil fuels have driven researchers to explore alternative fuels for internal combustion engines. Among various options, acetylene has emerged as a promising candidate due to its high flame velocity, wide flammability limits, and lower ignition energy requirements. This study presents an experimental investigation of acetylene as a supplementary fuel in a spark ignition (SI) engine. The performance parameters such as brake thermal efficiency, specific fuel consumption, and exhaust gas temperature were analyzed under different operating conditions. Emission characteristics including carbon monoxide (CO), unburned hydrocarbons (HC), carbon dioxide (CO<sub>2</sub>), and oxides of nitrogen (NO<sub>x</sub>) were also measured. The results indicate that acetylene enrichment leads to improved combustion efficiency and reduced CO and HC emissions compared to gasoline operation, although a marginal increase in NO<sub>x</sub> emissions was observed due to higher in-cylinder temperatures. Overall, the study demonstrates that acetylene has the potential to serve as a clean-burning alternative fuel in spark ignition engines, contributing to reduced dependence on petroleum-based fuels and mitigating environmental impacts.

**Keywords:** Alternative Fuel, Spark Engine, Acetylene, Performance, Emission,

---

## 1. INTRODUCTION

The global transportation sector is highly dependent on petroleum-derived fuels, which are associated with rapid depletion of fossil reserves, rising fuel costs, and increasing environmental pollution. Internal combustion (IC) engines, particularly spark ignition (SI) engines, continue to play a dominant role in mobility and power generation. However, their reliance on gasoline contributes significantly to greenhouse gas emissions and urban air pollution. To address these challenges, researchers are continuously exploring alternative fuels that are renewable, cost-effective, and environmentally sustainable [1]. In the present context, the world is confronted with the twin crisis of fossil fuel depletion and environmental Degradation. Conventional hydrocarbon fuels used by internal combustion engines, which continue to dominate many fields like transportation, agriculture, and power generation leads to pollutants like HC (hydrocarbons), Sox( sulphur oxides), and particulates which are highly harmful to human health. CO<sub>2</sub> from Greenhouse gas increases global warming [2]. This crisis has stimulated active research interest in non-petroleum, a renewable and non-polluting fuel, which has to promise a harmonious correlation with sustainable development, energy conservation, efficiency, and environmental preservation. Promising alternate fuels for internal combustion engines are natural gas, liquefied petroleum gas (LPG), hydrogen, acetylene, producer gas, alcohols, and vegetable oils. Among these fuels, there has been a considerable effort in the world to develop and introduce alternative gaseous fuels to replace conventional fuel by partial replacement or by total replacement. Many of the gaseous fuels can be obtained from renewable sources [3]. They have a high self-ignition temperature; and hence are excellent spark ignition engine fuels. They cannot be used directly in petrol engines However, Petrol

engines can be made to use a considerable amount of gaseous fuels in dual fuel mode without incorporating any major changes in engine construction [4]. It is possible to trace the origin of the dual fuel engines to Rudolf Petrol, who patented an engine running on essentially the dual-fuel principle. Here gaseous fuel called primary fuel is either inducted along with air intake, or injected directly into the cylinder and compressed, but does not auto-ignite due to its very high self-ignition temperature. Ignition of homogeneous mixture of air and gas is achieved by timed injection of small quantity of petrol called pilot fuel near the end of the compression stroke. [5] Conducted experiments on a diesel engine aspirated acetylene along with air at different flow rates without dual fuel mode. They carried out the experiment on a single cylinder, air cooled, direct injection (DI), compression ignition engine designed to develop the rated power output of 4.4 kW at 1500 rpm under variable load condition. Acetylene aspiration results came with a lower thermal efficiency reduced Smoke, HC and CO emissions, when compared with baseline diesel operation. [5] studied suitability of acetylene in SI engine along with EGR, and reported that emission got drastically reduced on par with hydrogen engine with marginal increase in thermal efficiency. [6] conducted experiments on a four-stroke, single cylinder, direct injection diesel engine fueled with natural gas. Tests were conducted with diesel as the pilot fuel having different cetane numbers in order to find the effects of pilot fuel quality on ignition delay. They concluded that ignition delay of a dual fuel engine mainly depends on pilot fuel quantity and quality. High cetane number pilot fuels can be used to improve performance of engines using low cetane value gaseous fuel. [7] conducted experiments on sole acetylene fuel in HCCI mode and shown the results with high thermal efficiencies in a wide range of BMEP. The thermal efficiencies were comparable to the base diesel engine and a slight increase in brake thermal efficiency was observed with optimized EGR operation. The intake charge temperature and amount of EGR have to be controlled based on the output of engine and at high BMEPs hot EGR leads to knock. [8] Price described the explosion of an acetylene gas cylinder, which occurred in 1993 in Sydney. The failure caused severe fragmentation of the cylinder and resulted in a fatality and property damage. He examined the nature of the explosion which occurred and sought an explanation of the events. He gave more information to prevent accidents regarding while using acetylene and the reactions take place in combustion and safety precautions. [9] Concluded that hydrogen can be inducted along with air to improve the performance and reduce hydrocarbons and smoke emissions of a Jatropa oil fuelled compression ignition engine with cleared dual fuel mode concept. The most significant environmental penalty will be an increase of NO emission. The amount of hydrogen that can be added depends on the output. At full load 7% of the total mass of fuel admitted has to be hydrogen for optimal performance. At low outputs it is not advantages to use hydrogen induction. Gaseous fuels such as hydrogen, liquefied petroleum gas (LPG), compressed natural gas (CNG), and producer gas have been extensively studied due to their clean-burning nature and ease of mixing with air. Among them, acetylene ( $C_2H_2$ ) has drawn attention as a potential alternative fuel for SI engines. Acetylene possesses favorable combustion characteristics, including a high flame propagation speed, a wide flammability range, and lower ignition energy compared to conventional fuels. These properties enable more complete combustion, resulting in reduced carbon monoxide (CO) and unburned hydrocarbon (HC) emissions. Moreover, acetylene can be produced from calcium carbide and water, or through biomass gasification, offering potential pathways for sustainable production [10].

Despite these advantages, challenges remain in utilizing acetylene as a fuel. Its high auto-ignition temperature and low energy density can affect engine performance, while increased in-cylinder temperatures may lead to higher nitrogen oxide (NO<sub>x</sub>) emissions. Therefore, careful optimization of the fuel delivery system and operating parameters is essential to achieve efficient and safe operation.

This study focuses on the experimental investigation of acetylene as an alternative fuel in a spark ignition engine, with the primary aim of evaluating its performance, combustion, and emission characteristics. By comparing the results with conventional gasoline operation, the feasibility of acetylene as a sustainable alternative fuel is assessed. The outcomes of this research are expected to contribute to the ongoing efforts toward reducing fossil fuel dependency and mitigating environmental pollution in the automotive sector.

## 2. MATERIALS AND METHODS

### 2.1 Acetylene production

Acetylene (C<sub>2</sub>H<sub>2</sub>) is colorless gas used as a fuel and a chemical building block. As an alkyne, acetylene is unsaturated because its two carbon atoms are bonded together in a triple bond having CCH bond angles of 180°. It is unstable in pure form and thus is usually handled as a solution. Pure acetylene is odorless, but commercial grades usually have a marked odor due to impurities. In 1836 acetylene identified as a "new carburet of hydrogen" by Edmund Davy. The name "acetylene" was given by Marcellin Berthelot in 1860. He prepared acetylene by passing vapours of organic compounds (methanol, ethanol, etc.) through a red-hot tube and collecting the effluent. He also found acetylene was formed by sparking electricity through mixed cyanogen and hydrogen gases. Berthelot later obtained acetylene directly by passing hydrogen between the poles of a carbon arc.

For commercial purposes, acetylene can be made from several different raw materials depending on the process used. Acetylene can be primarily produced by any of the following methods:

- By passing hydrocarbon with an electric arc.
- By reaction of water with calcium carbide.
- Partial combustion of methane with air/oxygen.

The simplest process for the production of acetylene is calcium carbide reacts with H<sub>2</sub>O and produce acetylene gas and calcium carbonate slurry, called hydrated lime. The chemical reaction may be written as

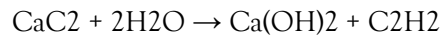

### 3. Experimental work

The experimental investigations were conducted on a single-cylinder, four-stroke, water-cooled spark ignition (SI) engine coupled to an eddy current dynamometer for applying load and measuring torque. The test engine was equipped with a conventional carburetor system for baseline gasoline operation, while acetylene was supplied through a separate fuel line. The acetylene cylinder was connected to the engine intake manifold via a pressure regulator, flashback arrestor, non-return valve, and a calibrated rotameter to control and measure the gas flow. A changeover valve was used to switch between gasoline and acetylene operation. The intake system included an air filter and a mixing chamber to ensure a homogeneous charge of acetylene-air mixture before entering the combustion chamber. The exhaust gases were sampled using a probe and analyzed for CO, HC, CO<sub>2</sub>, and NO<sub>x</sub> using a five-gas analyzer, while exhaust gas temperature was measured with thermocouples. A data acquisition system was employed to record key parameters including speed, torque, fuel consumption, and exhaust emissions. Proper safety precautions were taken by incorporating a flashback arrestor in the acetylene line and ensuring adequate ventilation. This experimental setup facilitated the performance and emission comparison of acetylene with conventional gasoline under varying engine load conditions.

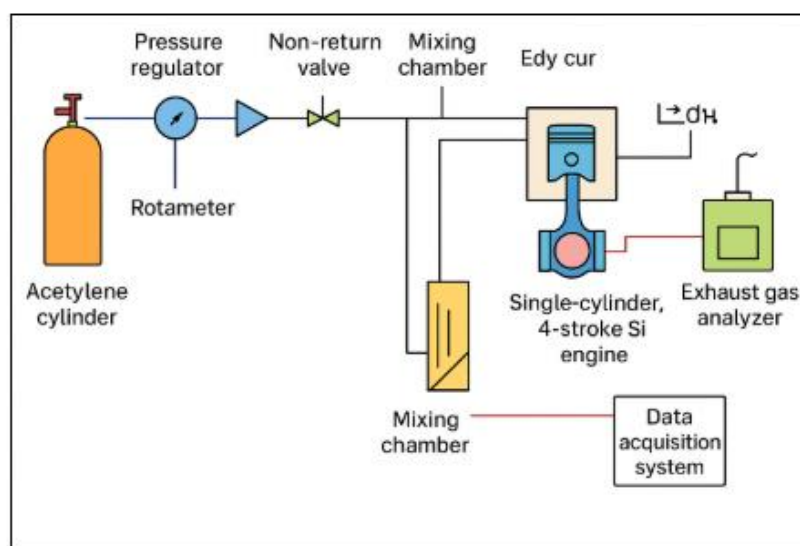

Figure 1. Schematic view of the experimental setup

Table 1 Physical and Combustion Properties of Acetylene Gas

Properties	Acetylene
------------	-----------

Formula	C <sub>2</sub> H <sub>2</sub>
Density kg/m <sup>3</sup> (At 1 atm & 200 C)	1.092
Auto ignition temperature (OC)	305
Stoichiometric air Fuel ratio, (kg/kg)	13.2
Flammability limits (volume %)	2.5 - 81
Flammability limits (equivalent ratio)	0.3 - 9.6
Lower Calorific Value (kJ/kg)	48,225
Lower calorific Value (kJ/m <sup>3</sup> )	50,636
Max deflagration Speed (m/sec)	1.5
Ignition energy 3333(MJ)	0.019
Lower heating Value of stoichiometric mixture (kJ/kg)	3396

#### 4. RESULTS AND DISCUSSION

##### Brake thermal efficiency

The variation of brake thermal efficiency (BTE) for gasoline and acetylene-gasoline dual fuel operation was studied at different load conditions. It was observed that the BTE of the engine running with pure gasoline was lower compared to the acetylene-enriched modes. When acetylene was supplied at a flow rate of 500 g/h along with gasoline, a noticeable improvement in thermal efficiency was achieved across the load range. This can be attributed to the higher flame propagation speed and wider flammability limits of acetylene, which promote faster and more complete combustion, thereby reducing cycle-to-cycle variations. Further enhancement in BTE was obtained with 1000 g/h of acetylene addition, where the engine consistently exhibited higher efficiency compared to both gasoline and the 500 g/h acetylene mode. The maximum BTE was recorded at full load with 1000 g/h acetylene enrichment, indicating that the dual fuel strategy improves combustion efficiency and better utilizes the supplied energy. However, the degree of improvement was more significant at medium and higher loads, suggesting that acetylene supplementation is particularly effective under conditions of higher energy demand [11].

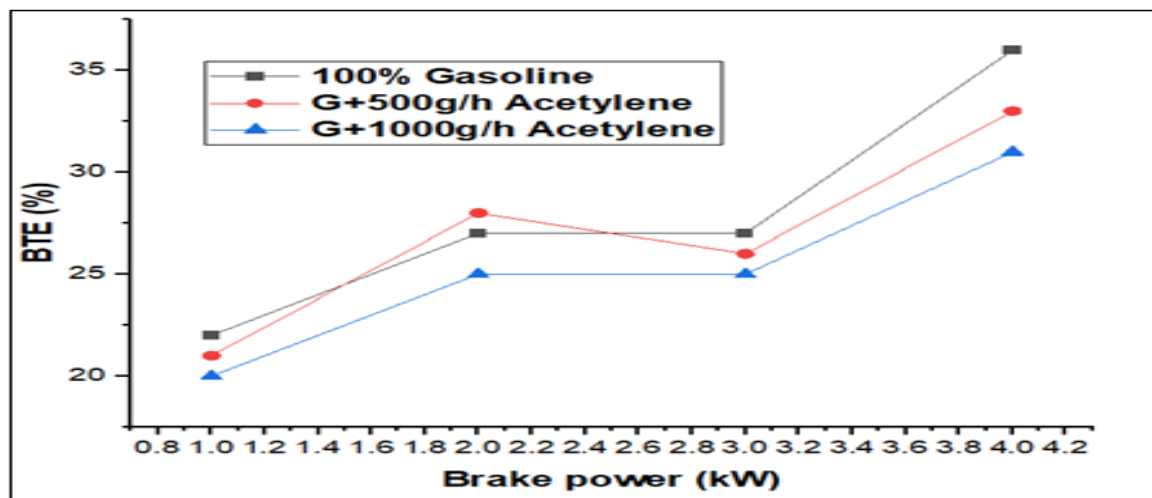

Figure 1. Variation of brake thermal efficiency with brake power

##### Brake specific fuel consumption (BSFC)

The brake specific fuel consumption (BSFC) was found to decrease when acetylene was introduced along with gasoline compared to operation with pure gasoline. For baseline gasoline mode, BSFC values were relatively higher due to incomplete utilization of the fuel energy and slower combustion. With 500 g/h acetylene enrichment, BSFC showed a noticeable reduction across the load spectrum, as acetylene's high flame speed and wider flammability limits enhanced the combustion process and improved thermal efficiency. At 1000 g/h acetylene flow rate, the BSFC decreased further, particularly at medium and higher loads, indicating more efficient utilization of the energy supplied to the engine. The lowest BSFC was observed at full load under 1000 g/h acetylene enrichment, which aligns with the observed improvements in brake thermal efficiency. These results confirm that acetylene supplementation reduces

the fuel consumption required per unit brake power output, thereby enhancing the overall fuel economy of the engine [12].

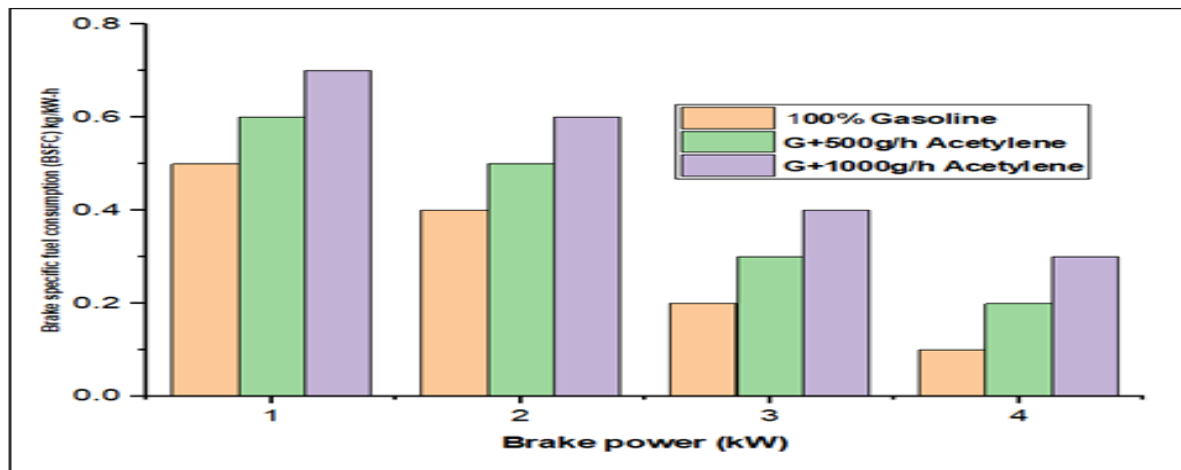

Figure 2. Variation of Brake specific fuel consumption with brake power Exhaust gas temperature (EGT)

The exhaust gas temperature (EGT) exhibited noticeable variation depending on the fuel mode and load condition. In pure gasoline operation, the EGT increased steadily with engine load due to greater fuel consumption and higher in-cylinder heat release. When acetylene was introduced at a flow rate of 500 g/h along with gasoline, a moderate rise in EGT was observed compared to baseline gasoline operation. This increase is attributed to the higher flame propagation velocity of acetylene, which promotes faster combustion and results in elevated in-cylinder peak temperatures. With 1000 g/h acetylene enrichment, the EGT values further increased across the load range, reaching their maximum at full load. The higher EGT in this case is linked to the intense combustion process and enhanced energy release from the acetylene-rich mixture. Although elevated EGT reflects improved combustion efficiency, it also indicates higher thermal loading on engine components, which may require careful thermal management for long-term operation [13].

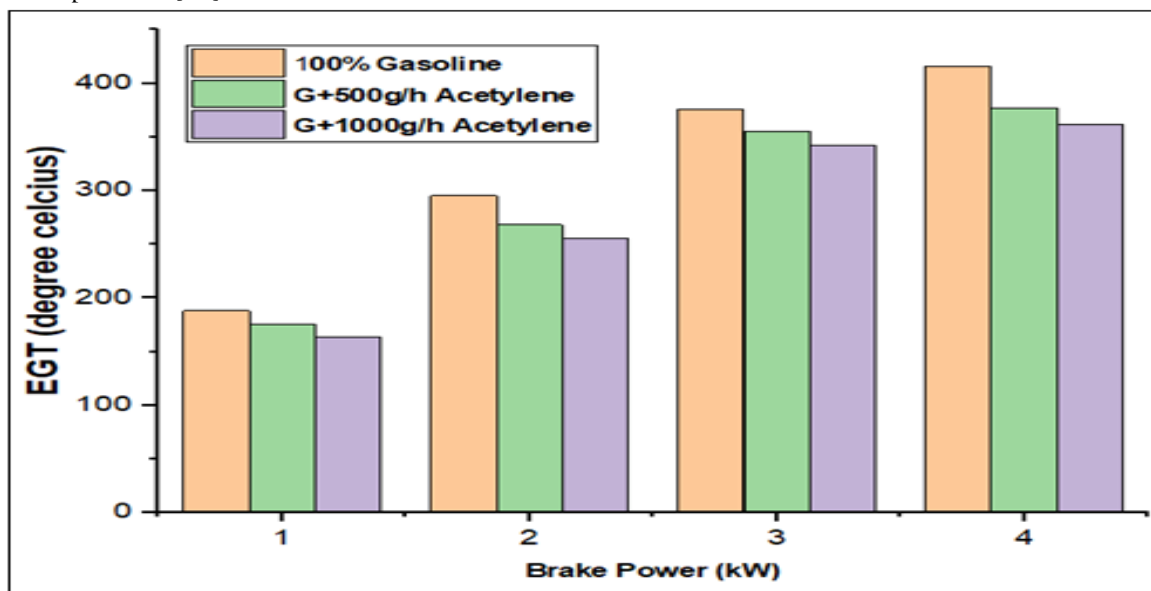

Figure 4. Variation of exhaust gas temperature with brake power

#### Engine emission characteristics

The emission characteristics of the engine varied significantly with the introduction of acetylene into the gasoline fuel stream. In pure gasoline mode, higher concentrations of carbon monoxide (CO) and unburned hydrocarbons (HC) were observed, particularly at lower and medium loads, due to incomplete

combustion and slower flame propagation. With the enrichment of 500 g/h acetylene, a clear reduction in CO and HC emissions was recorded across all load conditions. This improvement can be attributed to acetylene's high flame velocity and wider flammability limits, which ensured more complete combustion of the charge. At 1000 g/h acetylene flow, CO and HC emissions decreased further, reaching their lowest values at higher loads, thus demonstrating superior oxidation of the fuel mixture. However, the enhanced combustion led to an increase in exhaust gas temperature, which in turn promoted the formation of nitrogen oxides (NO<sub>x</sub>). The NO<sub>x</sub> emissions were noticeably higher under 1000 g/h acetylene enrichment compared to both gasoline and the 500 g/h mode. Carbon dioxide (CO<sub>2</sub>) emissions showed a marginal increase with acetylene addition, which is consistent with the improved combustion efficiency and complete oxidation of carbon species. Overall, the dual fuel operation with acetylene demonstrated a trade-off, offering significant reductions in CO and HC emissions at the expense of slightly higher NO<sub>x</sub> levels.

#### Hydrocarbon (HC) emissions

The variation of hydrocarbon (HC) emissions with different fuel modes indicated a strong influence of acetylene enrichment on combustion completeness. In pure gasoline operation, HC emissions were relatively higher across the load range, with the maximum values occurring at lower and part loads. This trend can be attributed to incomplete combustion, fuel quenching near the combustion chamber walls, and cycle-to-cycle variations in the flame propagation. When acetylene was introduced at a flow rate of 500 g/h, HC emissions were substantially reduced, particularly at medium and higher loads. The improvement is linked to the higher flame velocity and broader flammability range of acetylene, which enhanced charge combustion and minimized unburned fuel. Further reduction in HC emissions was achieved with 1000 g/h acetylene enrichment, where the values dropped to their lowest levels at full load. This demonstrates that acetylene supplementation promotes faster and more complete oxidation of hydrocarbons compared to gasoline alone. However, a slight increase in HC at very low load with acetylene addition was noted, possibly due to flame quenching effects caused by localized lean mixtures. Overall, the results confirm that acetylene enrichment significantly improves combustion efficiency, leading to lower HC emissions and a cleaner exhaust profile.

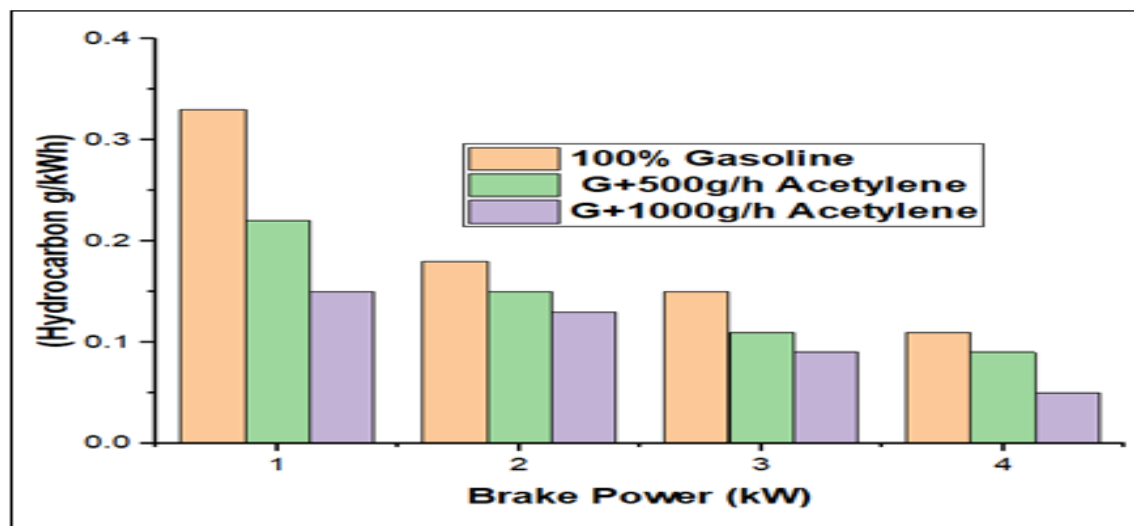

Figure 7. Hydrocarbon and brake power at different flow rate of acetylene

#### Carbon monoxide (CO) emissions

The analysis of carbon monoxide (CO) emissions revealed a significant improvement with acetylene enrichment compared to pure gasoline operation. In baseline gasoline mode, CO emissions were relatively high at low and medium loads due to incomplete combustion and insufficient oxygen availability in certain regions of the combustion chamber. The slow flame speed of gasoline also contributed to localized rich zones, resulting in partial oxidation of carbon to CO instead of CO<sub>2</sub>. With the introduction of 500 g/h acetylene, CO emissions showed a clear reduction across the load spectrum. This was mainly due to acetylene's high flame propagation rate and wider flammability limits, which

facilitated more uniform combustion and improved oxidation of carbon species. At 1000 g/h acetylene enrichment, CO emissions further decreased, reaching their minimum values at higher loads. The results indicate that acetylene supplementation effectively enhances combustion efficiency by reducing the presence of unburned or partially burned carbon, thereby minimizing CO emissions. The overall trend confirms that acetylene-gasoline dual fuel operation leads to a cleaner exhaust profile with respect to carbon monoxide compared to conventional gasoline operation.

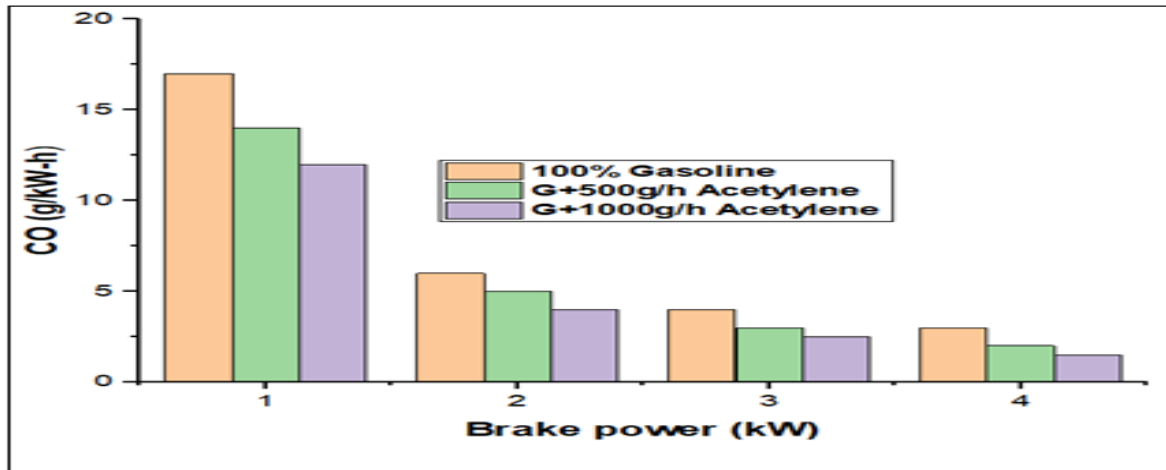

Figure 8. Variation in CO with brake power at various flow rate of acetylene

**Nitric oxide (NOx) emissions**

The emission of nitric oxides (NOx) showed an increasing trend with acetylene enrichment compared to baseline gasoline operation. In pure gasoline mode, NOx levels were relatively moderate, as combustion was slower and in-cylinder temperatures were lower. However, when acetylene was introduced at 500 g/h, NOx emissions increased noticeably across all load conditions. This rise can be attributed to acetylene’s higher flame velocity and faster combustion, which resulted in elevated peak cylinder pressures and higher combustion temperatures, favoring thermal NOx formation through the Zeldovich mechanism. At 1000 g/h acetylene enrichment, NOx emissions reached their maximum values, particularly at medium and full loads, where the in-cylinder temperature and oxygen availability were highest. Although acetylene addition improved combustion efficiency and significantly reduced CO and HC emissions, the corresponding increase in NOx highlights a key trade-off. The higher thermal loading associated with acetylene operation emphasizes the need for strategies such as exhaust gas recirculation (EGR), water injection, or ignition timing optimization to mitigate NOx formation while retaining the benefits of acetylene as a clean-burning fuel supplement.

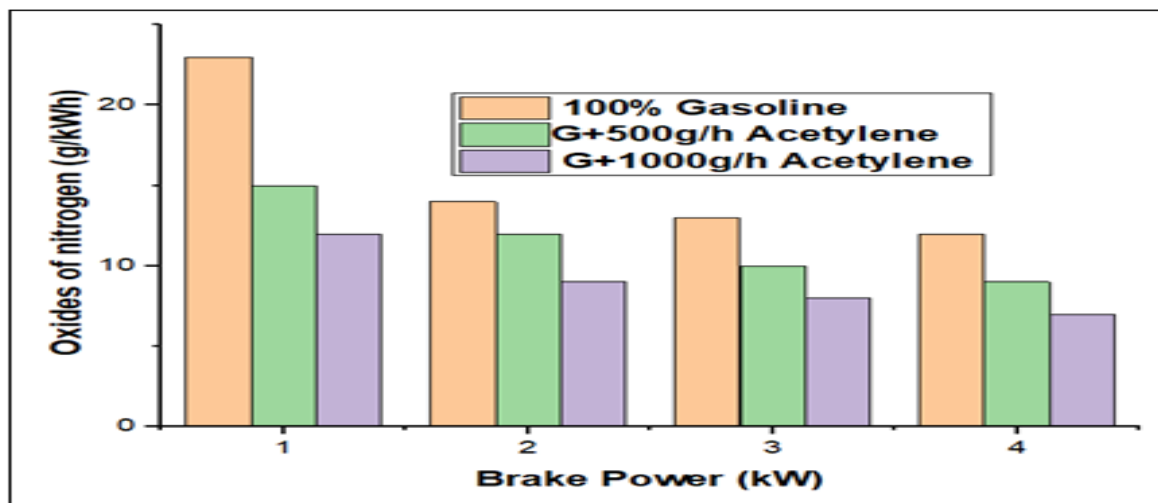

Figure 9. Oxides of nitrogen and brake power at different flow rate of acetylene

**CONCLUSION**

The experimental investigation on the utilization of acetylene as a supplementary fuel in a spark ignition engine demonstrated significant potential for improving engine performance and reducing harmful emissions. The brake thermal efficiency (BTE) increased consistently with acetylene enrichment, with the highest values obtained at 1000 g/h acetylene flow, indicating more effective energy conversion. Correspondingly, the brake specific fuel consumption (BSFC) decreased under dual-fuel operation, confirming enhanced fuel economy compared to pure gasoline. Exhaust gas temperature (EGT) was higher with acetylene addition, a result of faster combustion and elevated in-cylinder temperatures. In terms of emissions, acetylene supplementation markedly reduced carbon monoxide (CO) and hydrocarbon (HC) emissions due to more complete oxidation of the charge. Carbon dioxide (CO<sub>2</sub>) emissions showed a slight increase, reflecting improved combustion efficiency. However, nitric oxide (NO<sub>x</sub>) emissions were significantly higher under acetylene operation, particularly at higher loads, due to increased flame temperature and oxygen availability. Overall, the study establishes that acetylene can serve as a promising alternative fuel for spark ignition engines, offering improved efficiency and reduced incomplete combustion emissions. Nevertheless, the challenge of elevated NO<sub>x</sub> emissions highlights the need for further research into control strategies such as exhaust gas recirculation (EGR), ignition timing optimization, or after-treatment systems. With appropriate control measures, acetylene could contribute to the development of cleaner and more efficient internal combustion engine technologies.

## REFERENCE

- [1] Marrodan L, Berdusan L, Aranda V, Millera A, Bilbao R, Alzueta MU. Influence of dimethyl ether addition on the oxidation of acetylene in the absence and presence of NO. *Fuel* 2016; 183: 1-8. <https://doi.org/10.1016/j.fuel.2016.06.011>
- [2] Hoseinpour M, Sadriani H, Tabasizadeh M, Ghobadian B. Energy and exergy analyses of a diesel engine fueled with diesel, biodiesel-diesel blend and gasoline fumigation. *Energy* 2017; 141: 2408-2420. <https://doi.org/10.1016/j.energy.2017.11.131>
- [3] Basha, Shaik Khader, and P. Srinivasa Rao. 2016. "Experimental Investigation of Performance of Acetylene Fuel Based Diesel Engine." *International Journal of Advancements in Technology* 7 (1): 1-7. doi:10.4172/0976-4860.100 0151.
- [4] Ghazal, O.H., Combustion analysis of hydrogen-diesel dual fuel engine with water injection technique, *Case Studies in Thermal Engineering*, 2019. 13(100380):p.1-10
- [5] Ravi, K., Sachin Mathew, J. Pradeep Bhasker, and E. Porpatham. 2017. "Gaseous Alternative Fuels for Spark Ignition Engines - A Technical Review." *Journal of Chemical and Pharmaceutical Sciences* 10 (1): 93-99.
- [6] Özel S., Vural, E., M, Binici, Taguchi method for investigation of the effect of TBC coatings on NiCr bondcoated diesel engine on exhaust gas emissions, *International Advanced Researches and Engineering*, 2020. 04(01): p. 014- 020.
- [7] Yadav, Vinod Singh, Dilip Sharma, and S. L. Soni. 2015. "Performance and Combustion Analysis of Hydrogen-fuelled C.I. Engine with EGR." *International Journal of Hydrogen Energy* 40 (12): 4382-4391. doi:10.1016/j.ijhydene.2015.01.162
- [8] Kwon, Eui Chang, Kyeongsoo Song, Minsoo Kim, Youhwan Shin, and Sun Choi. 2017. "Performance of Small Spark Ignition Engine Fueled with Biogas at Different Compression Ratio and Various Carbon Dioxide Dilution." *Fuel* 196: 217-224. doi:10.1016/j.fuel.2017.01.105.
- [9] Jaikumar, S. and S.K., Bhatti, Srinivas, Experimental Explorations of Dual Fuel CI Engine Operating with Guizotia abyssinica Methyl Ester-Diesel Blend (B20) and Hydrogen at Different Compression Ratios, *Arabian Journal For Science and Engineering*, 2020. 44(12): p. 10195-10205.
- [10] Jhalani, A., D. Sharma, S. L. Soni, P. K. Sharma, and S. Sharma. 2019. "A Comprehensive Review on Water-emulsified Diesel Fuel: Chemistry, Engine Performance and Exhaust Emissions." *Environmental Science and Pollution Research*. doi:10.1007/s11356-018-3958-y.
- [11] Liu, Z., National carbon emissions from the industry process: Production of glass, soda ash, ammonia, calcium carbide and alumina, *Applied Energy*, 2019. 166(2019): p. 239-244.
- [12] İlhan, Mehmet İlhan, Selahaddin Orhan Akansu, Nafiz Kahraman, and Sebahattin Ünalan. 2018. "Experimental Study on an SI Engine Fuelled by Gasoline/Acetylene Mixtures." *Energy* 151: 707-714. doi:10.1016/j.energy. 2018.03.108.
- [13] İlhan, İ.İ., M., Doğan, R., Akansu, S.O., N., Kahraman, Experimental study on an SI engine fueled by gasoline, ethanol and acetylene at partial loads, *Fuel*, 2020. 261(2020): p.116148.
- [14] Özer, S. and E., Vural, Effects of CNG addition in a diesel engine using diesel/n-heptane, diesel/toluene as pilot fuel, *Gazi Mühendislik Bilimleri Dergisi*, 2020. 6(1): p.1-15.