

Conceptual Proposal For Functional Devices For Joint Application Of Design And Artificial Intelligence

Artashes Meliqyan¹, Ashot Baghdasaryan¹, Hovsep Stepanyan¹, Tamara Sargsyan¹, Anahit Petrosyan¹, Karen Meliqyan¹, Tatevik Paytyan^{1*}

¹Faculty of Design, National University of Architecture and Construction of Armenia, Yerevan, Armenia

*Corresponding Author: Tatevik Paytyan paytyantatevik@gmail.com

Abstract:

This article presents the features, beneficial commonalities, and potential areas of collaboration between artificial intelligence and Design methodologies. The aim is to present a significant innovation in the rapidly advancing field of design technology, which is anticipated to enhance the capabilities and functionality of design tools. This advancement is expected to address current challenges and create new opportunities for designers globally. Through an examination of the challenges and issues confronting design, the devices will possess functions with enhanced capabilities that will enable designers and architects to visualize and implement their concepts with unprecedented efficiency, time optimization, and precision. The functionalities of these devices will provide designers with a comprehensive perspective and information regarding their environment. Whether it pertains to documenting real-world environments, investigating spatial relationships, or presenting design concepts in virtual reality, this technology facilitates a novel realm of innovation and collaborative opportunities for designers. Furthermore, the device will incorporate advanced measurement tools that will enable precise spatial measurements, resulting in both three-dimensional modeling and two-dimensional drawings through the utilization of artificial intelligence algorithms. Through the precise acquisition of dimensional and spatial data, designers can ensure the accuracy and consistency of their designs from initial conceptual development to final implementation. Whether conceptualizing architectural designs, developing product prototypes, or creating complex illustrations, the device will enable designers to realize their visions with unprecedented efficiency and precision.

Keywords: Design methodology, Artificial intelligence, design project, device, process.

INTRODUCTION

For millennia, design has been a fundamental element of human progress, serving as a conduit between imagination and reality. However, in the 21st century, design is undergoing a renaissance, facilitated by an unexpected collaborator: artificial intelligence. This potent alliance does not aim to supplant human creativity, but rather to foster a synergy of innovation, wherein human intuition and machine intelligence operate in optimal concordance. Historically, design has been a human-centric discipline. Designers endeavor to comprehend users and their needs, translating these insights into solutions that are not only functional but also aesthetically refined and emotionally engaging. However, the rapid expansion of data in recent years has introduced challenges and opportunities. While the vast quantity of information offers the potential for deeper understanding, it also presents the risk of overwhelming designers, making it difficult to identify underlying patterns and user preferences. On the other hand, these data serve as crucial resources for gaining deeper insights into user behavior and facilitating the creation of highly personalized experiences. Artificial Intelligence (AI) has played a transformative role. With its capacity to process and analyze vast datasets, AI has emerged as a powerful tool for designers, enabling the identification of hidden trends, prediction of user preferences, and generation of multiple design alternatives—at a speed and scale far beyond human capability. As we advance, the synergy between design and artificial intelligence presents boundless potential. This powerful integration has the potential to transform not only the way products and services are designed but also how we interact with our surroundings. This marks a pivotal chapter in human history, where creativity and computation converge to shape a future that is more aesthetically refined, functionally efficient, and highly personalized.

Below is a journey through the dynamic “landscape” of design and artificial intelligence, exploring the multifaceted nature of their interactions, from real-world applications that are redefining industries to philosophical investigations that explore the nature of creativity and intelligence, delving into the heart of this growing nexus, seeking to uncover its complexities and chart a path to a future where innovation knows no boundaries.

This research focuses on exploring the intersection of design and artificial intelligence, examining their integration to enhance the effectiveness of design projects, and addressing various challenges. This endeavor necessitates a well-defined research methodology that includes the following:

- One of the foundational steps of the methodology is to clearly outline the design objectives and tasks that devices powered by artificial intelligence will carry out.
- Define the project's scope by considering project types, target audience, and expected outcomes.
- Conduct thorough research on design tools, technologies, and methodologies that complement artificial intelligence.
- Examine relevant literature and academic research papers on artificial intelligence in the areas of design, robotics, machine learning, and human-computer interaction.
- Determine the requirements and limitations when designing a robot powered by artificial intelligence, taking into account factors such as functionality, usability, safety, and performance.
- Define the technical specifications, including hardware components, software architecture, and artificial intelligence algorithms.
- Conduct user research to identify the needs, preferences, and behaviors of potential users or stakeholders.
- Generate concepts and ideas for a robot powered by artificial intelligence, based on specific goals, requirements, and user insights.
- Explore possible design solutions while taking into account factors such as form, function, interaction, and user experience.
- Develop prototypes of AI-powered equipment to evaluate and confirm design concepts and functionality.
- Utilize rapid prototyping techniques such as 3D printing, laser cutting, or Arduino-based development to iterate on design ideas and improve hardware features.
- Create artificial intelligence models and algorithms for equipment to autonomously conduct design tasks.
- Select suitable machine learning methods like deep learning, reinforcement learning, or computer vision according to the specific design tasks and requirements.
- Integrate artificial intelligence models with hardware components, including sensors, motors, and controllers.
- Create or modify hardware solutions to enhance AI-powered functions, ensuring they are compatible, reliable, and perform optimally.

MATERIAL AND METHODS

Design methodology is a structured and systematic approach that enables designers to tackle complex challenges and develop innovative solutions. It serves as a guiding framework, leading designers through key stages, such as problem analysis, idea generation, prototyping, and evaluation. At its core, a design methodology is founded on the fundamental principle that a comprehensive understanding of the problem must precede any attempt to devise a solution.

Designers begin by conducting thorough research, delving into the needs of users, market trends, and the context of the problem. This empathetic approach, often referred to as design thinking, allows designers to gain a deep understanding of the target audience, ensuring that the subsequent design process meets their specific needs.

The design process generally comprises a series of interconnected phases, each playing a crucial role in the overall success of the project. While these phases may vary depending on the specific design discipline and complexity of the project, they typically include the following:

1. Research and discovery: Gathering information and conducting user research to identify pain points and opportunities.
2. Brainstorming and Conceptualization: Brainstorming and generating a wide range of creative ideas to solve identified problems.
3. Prototyping: Building prototypes, whether low-fidelity sketches or high-fidelity digital models, to visualize and test the proposed design solutions.
4. Evaluation and testing: Gathering feedback from users and stakeholders and conducting usability testing to validate and refine prototypes.

5. Implementation and repeat: Development of the final design and continuous improvements based on user feedback. The role of design frameworks is crucial; they provide a structural approach to the design process, enabling designers to collaborate effectively with their teams. Some widely used frameworks include Design Thinking, Double Diamond, LERE UX, and Agile Design. Each framework has its unique strengths, but all emphasize human-centered design and collaboration.

Impact on Creativity and Innovation:

Design methodology fosters a culture of creativity and innovation by encouraging systematic exploration of diverse ideas and concepts. This approach enables designers to move beyond conventional solutions and experiments by using novel approaches. Furthermore, the iterative nature of the design process supports continuous refinement and improvement, cultivating an experimental mindset and a willingness to embrace change.

User-Centered Design and Empathy: A fundamental principle of design methodology is user-centered design, which emphasizes the importance of understanding users' needs, motivations, and challenges. By engaging deeply with users, designers can create products and services that genuinely address their requirements. This empathetic approach fosters meaningful connections between designers and users, ensuring that the final solutions are not only functional, but also resonate with the intended audience (1).

Design methodology transcends a mere process; it constitutes a cognitive framework that cultivates creativity, innovation, and user-centered design. Through the implementation of a structured approach and the utilization of design frameworks, practitioners can efficiently address complex challenges, resulting in substantive and impactful solutions.

The adoption of design methodology enables designers to reconcile creative and practical considerations, resulting in successful outcomes that have a positive impact on users and society at large. As the design industry undergoes continuous evolution, a comprehensive understanding of design methodology remains crucial for designers to excel and make enduring contributions in their respective fields. The following prerequisites are defined:

1. Identify the problem: clearly define the need that the project aims to solve.
2. Research and collecting information: Conduct research and collect relevant data to understand the context, users, and constraints.
3. Define goals and constraints that guide the design process. Generate ideas/solutions: Brainstorm and develop different ideas and solutions to solve the identified problem.
4. Prototyping and Testing: Create prototypes or models to test the feasibility and effectiveness of the design solutions.
5. Evaluate and Iterate: Collect feedback from the testing and evaluation processes and iterate the design to improve it.
6. Final design: When the design meets the requirements and goals, the project is finalized for implementation or production.

RESULT AND DISCUSSION

The research has elucidated the current possibilities, trends, and operational significance of the proposed methods, while simultaneously revealing the complex and interrelated aspects of the design methodology, which has led to the conceptualization of the interaction between these two facets. Artificial intelligence algorithms have attained a level of sophistication that facilitates accurate image recognition and three-dimensional modeling, while virtual reality technology provides an immersive user experience that was previously unattainable.

The proposed research endeavor entails the development of an advanced apparatus utilizing artificial intelligence to analyze, model, and modify both interior and exterior environments in real time. This device will be equipped with virtual reality goggles and panels that will enable users to visualize and interact with the modified environment within a virtual space.

The project utilizes several key components and devices: a high-resolution camera-scanner for capturing, scanning, and modeling detailed images of the environment; VR/AR glasses that enable users to make real-time changes and are equipped with artificial intelligence for data processing and model creation; an interactive control panel; a handle; a tripod for adjusting and positioning the scanner; a charging device; and a drone (Fig. 1).

The core of this project will be software components that incorporate artificial intelligence algorithms for image recognition, 3D modeling, and real-time modifications. It will also include a database for storing various design options and configurations. The project's goal is to revolutionize architecture, landscape and interior design, and real estate by providing a comprehensive solution for creating, visualizing, and modifying three-dimensional models of spaces in real-time. By integrating various technologies simultaneously, the device aims to simplify the design process, enhance the user experience, and provide a competitive edge in the market. This will enable professionals in relevant fields to visualize changes with a more realistic perspective, easily switch between different configurations and design concepts, improve presentation methods for clients, and even conduct virtual tours. As the demand for innovative solutions in architecture and design continues to grow, this device will serve as an excellent tool to boost creativity, efficiency, and decision-making in the design process (3).



Figure 1: Complete design: 1-scanner, 2-handle, 3-charger, 4-tripod, 5-VR-AR glasses, 6-UAV, 7-control panel

The ability to visualize and modify spaces in real time meets a significant market demand. Advances in artificial intelligence and virtual reality technologies make this project not only feasible but also highly relevant. The device will prioritize user experience, which will include: - **Ease of Use:** An intuitive interface that enables users to learn and operate the device quickly. - **Customizability:** Options to tailor the device's functionality to meet individual needs and preferences. - **Support and Training:** Comprehensive support and training resources to ensure users can fully leverage the device's capabilities. To enhance its usefulness, the device will be compatible with existing design software and tools. It offers a competitive advantage through a unique combination of AI-powered modeling and VR visualization, making it stand out in the market. The device addresses the challenges of traditional design processes by providing a modern solution that is both efficient and appealing. It integrates with popular CAD programs to streamline workflows, utilizes storage and processing capabilities to handle large data sets, and facilitates collaboration. Additionally, mobile applications will be available to extend the device's functionality and accessibility. By merging advanced hardware with cutting-edge technologies, this project tackles key challenges in the industry and meets the increasing demand for innovative design solutions. With its user-centric design and seamless integration, this device has the potential to transform workflows. It is set to become an essential tool for professionals looking to enhance their creative and decision-making processes. The program's relevance and focus align with current market trends and technological advancements, making it a timely and valuable addition to the industry. Below is an overview of the structure, flow, direction, and component elements of the design concept (Fig. 2):

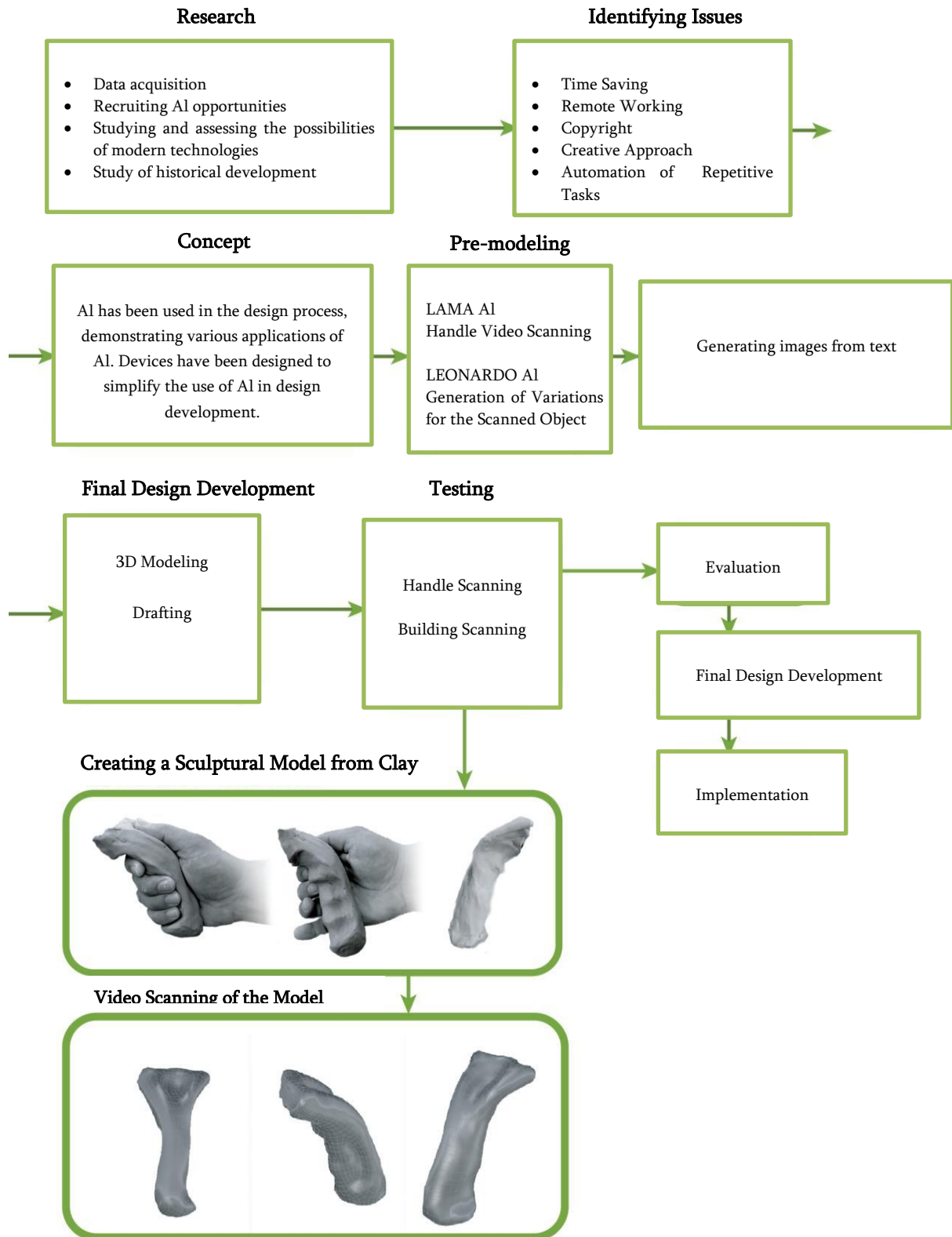
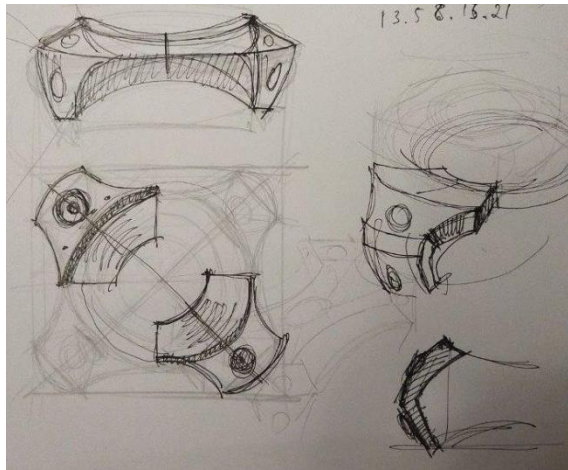

Figure 2: Description of the work performed

The project proposal outlines a range of innovative technologies, which were presented briefly and are now explained in greater detail.

1. SCANNER

A modern modular scanner integrated with artificial intelligence is shown (Fig. 3). This device, consisting of four interconnected modules, offers versatile functions for various applications, including 3D scanning, video recording, and real-time environmental modeling. The modular structure and design allow for flexibility in its use, allowing users to deploy one to four modules based on specific requirements and adapt to different operational needs.



Figure

3:

Sketching work

The device aims to enhance the skills of professionals in architecture, interior design, and real estate by offering a multifunctional tool for drawing and modeling environments. With the integration of artificial intelligence, it ensures high accuracy and efficiency, making it an invaluable resource for creating detailed 3D models and immersive virtual experiences.

Single module use (Fig. 4): This is ideal for scanning small objects or when portability is important. It is mainly used with human intervention. The object should be placed in the center, while the person rotates the scanner around it using a handle.

Figure. 4: Single scanner module



Using a dual module: Provides enhanced coverage and accuracy for medium-sized environments (Fig. 5, 6).



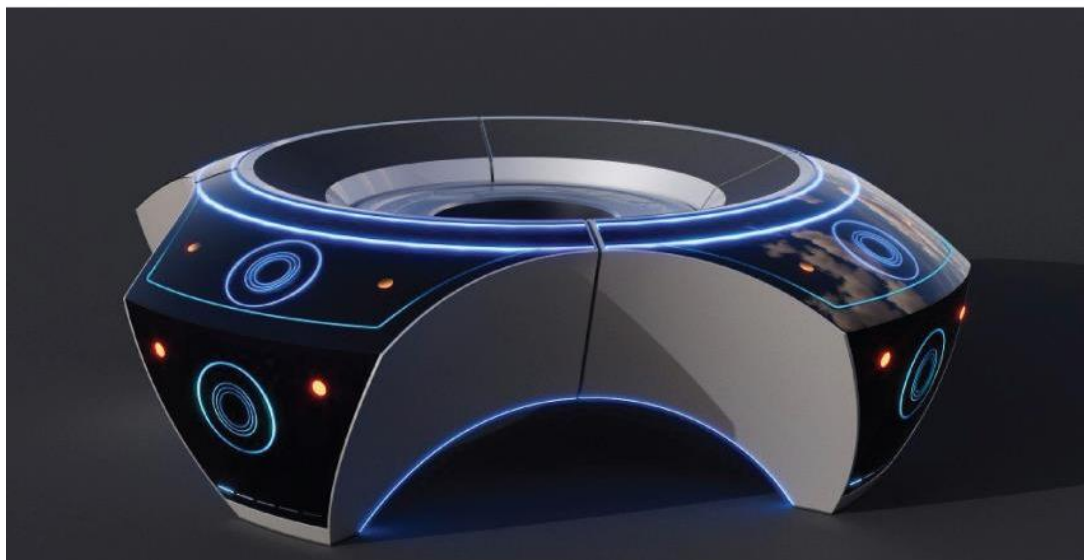

Figure 5: Dual scanner module **Figure 6:** Triple module usage: Provides a balanced approach for more complex tasks.

Quad module. Using a quad module provides maximum coverage and accuracy, making it ideal for large-scale projects (Fig. 7). This option is preferred because it allows the scanner to offer 360-degree visibility, regardless of its rotation angle, position, or axis. Three levels of rotation are performed in all cases to accurately capture the environment. For exterior projects, a drone may be necessary to navigate large-scale obstacles.

Figure 7: Quad scanner module

Each module is designed to connect seamlessly with others, ensuring stability and synchronization. One module includes several important hardware components: it has two high-resolution cameras (Fig. 8) that can scan wide-angle scenes, detailed images, and video.

Figure 8: Scanner cameras

Each camera can shoot at a 140-200-degree angle (however, the optimal option is a 140-degree angle (Fig.



9), reducing image distortion, reduction, and measurement error) through an internal "lens."

Figure 9: Scanner lens shooting angle

These cameras are designed to perform multiple functions, each contributing to the device's overall performance and versatility. They are equipped with advanced CMOS or CCD sensors capable of capturing high-resolution images. This technology enables the device to create detailed and sharp images, which are essential for accurately scanning the environment and ensuring the quality of the final results. Autofocus, which addresses one of the challenges associated with remote work, utilizes contrast detection or phase detection methodologies. This technology is particularly advantageous in dynamic environments where the distance between the camera and the subject may fluctuate. The cameras automatically adjust exposure parameters based on ambient lighting conditions, thereby ensuring that the resulting images are neither overexposed nor underexposed.

This is accomplished through real-time analysis of scene luminosity and dynamic range adjustment. The cameras utilize automatic white balance (AWB) to correct colors from diverse illumination sources, ensuring precise color reproduction. The device incorporates stereo camera configurations for depth perception and three-dimensional imaging. This functionality enables the device to capture the three-dimensional structure of objects, which is advantageous for 3D modeling and augmented reality applications.

Advanced techniques such as structured light and Time-of-Flight (ToF) sensors can be integrated to enhance depth perception capabilities, thereby providing more accurate three-dimensional data. The device is capable of capturing multiple overlapping images and subsequently combining them to generate high-resolution panoramic images. Integrated image processing algorithms enhance captured images by mitigating noise, rectifying distortions, and improving overall clarity.

This approach ensures the optimization of the final result's quality. The scanner rotates around three central, divided frames in three coordinate axes (x, y, z). The modules are affixed to the central frames utilizing their protrusions (Fig. 10).

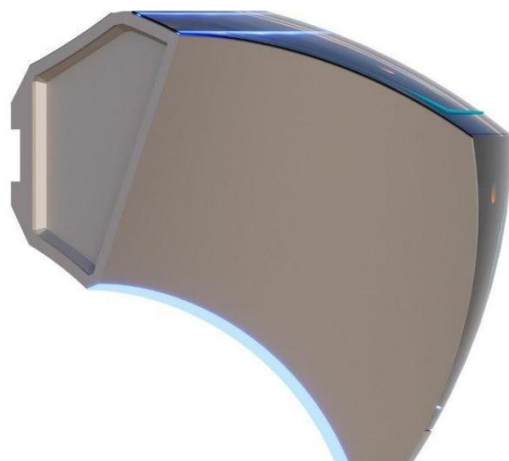

Figure 10: Module protrusion

The inclined surfaces of each module facing the frames are composed of rubber material, facilitating ergonomic manual operation.

The scanner will operate via Wi-Fi or Bluetooth to facilitate wireless image transfer to computers and smartphones. This enhances the efficiency and rapidity of data processing. USB and HDMI connectivity will be provided for expeditious data transfer and real-time display on external monitors. Below: Exploded diagram of the scanner (Fig. 11).

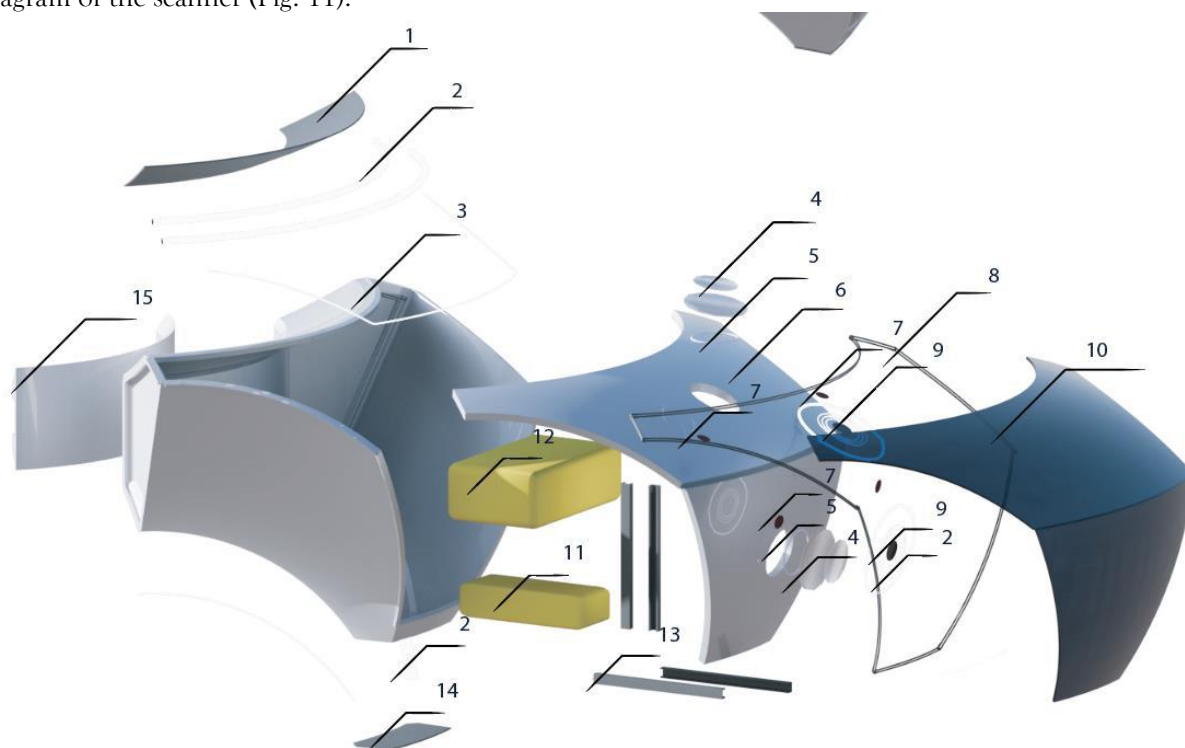

Figure 11: Exploded diagram: 1-rubber, 2-decorative light, 3-general body, 4-lens, 5-spacer, 6-inner body, 7-lidar, 8-large body spacer, 9-objective, 10-glass, 11-software camera, 12-battery, 13-internal structure, 14-leg, 15-coupling.

1. HANDLE:

The design and development of a handle adapted for the scanner is a complex process that incorporates both anthropometric considerations and advanced technology. It is engineered to facilitate scanner movement, execute the rotation process, and enhance the scanner's functionality, user comfort, and operational efficiency. A working test for a specialized handle-device for the scanner was conducted utilizing artificial intelligence (Fig. 12).

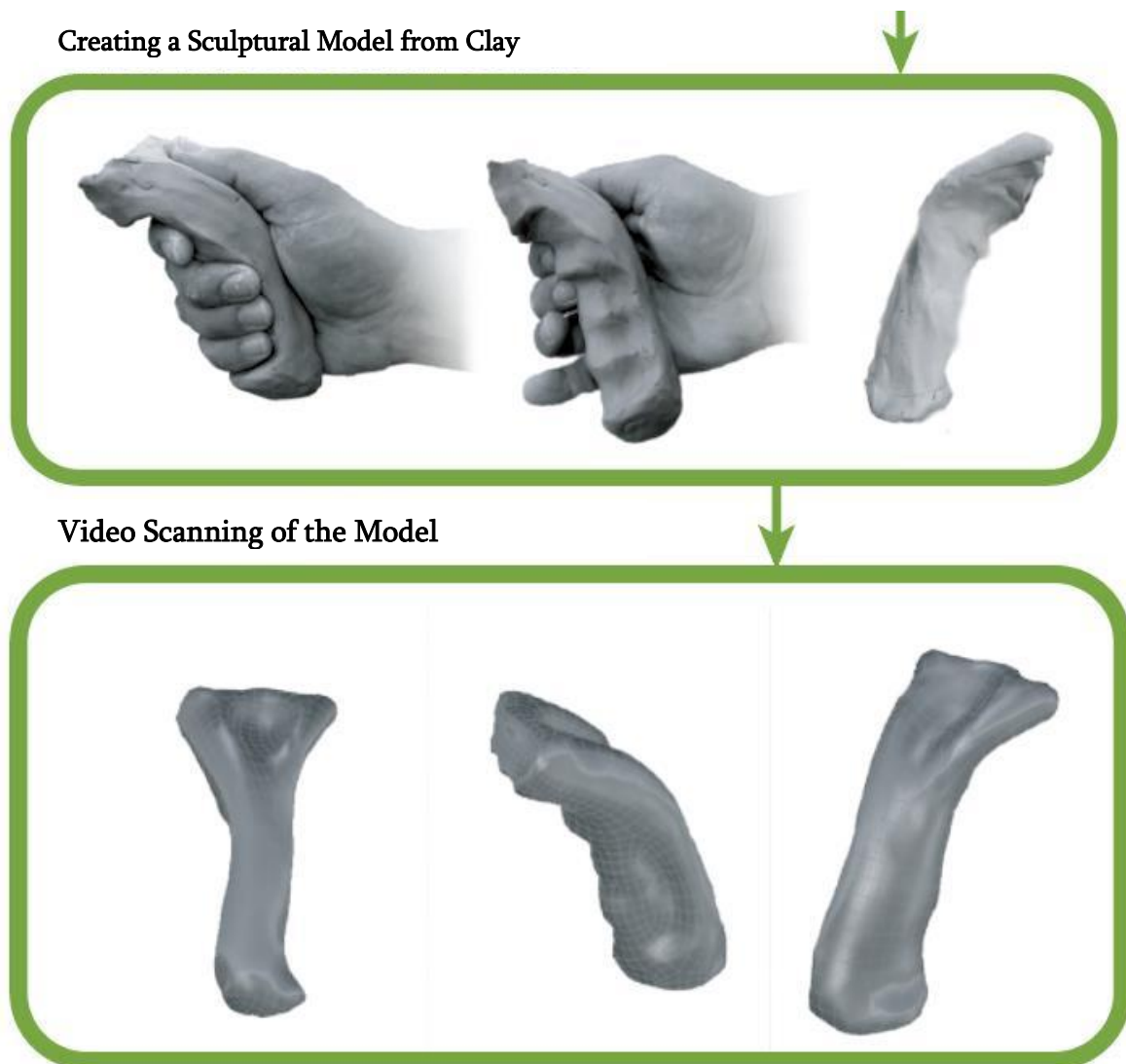

Figure 12: Work test with clay; video scan of the model

Clay was selected as the initial material for the prototype due to its flexibility and ease of use. This choice enables quick iterations and hand modeling to achieve the basic shape of the handle. A rough prototype was created using clay, incorporating the fundamental position of the fingers. This prototype was video recorded, providing a reference for the subsequent digital modeling process.

The artificial intelligence system processed the scanned data to generate a preliminary 3D model of the handle, accurately converting the physical prototype into a digital format. This model was then analyzed to identify critical features that needed modifications for enhanced ergonomics and functionality. Subsequently, the 3D model was adjusted to align more closely with the anatomical features of the human hand.

The process involved refining the contours of the handle, smoothing out the edges, and optimizing its overall shape to ensure a comfortable and secure grip during use. We conducted iterative testing and made refinements using both virtual simulations and physical prototypes to validate the ergonomic design.

The aim of the experiment was to replicate the phase sequence and results of the project using photogrammetry, which would clarify the current problems, advantages, disadvantages, and details of the project. To ensure the handle design is accessible and comfortable for a diverse range of users, the inner part of the handle is identical on both sides. Instead, a lower part that can be rotated around the axis was added, allowing it to adapt to both left-handed and right-handed individuals. The handle features multiple directions of rotation, transformation extensions, and various options (Fig. 13).

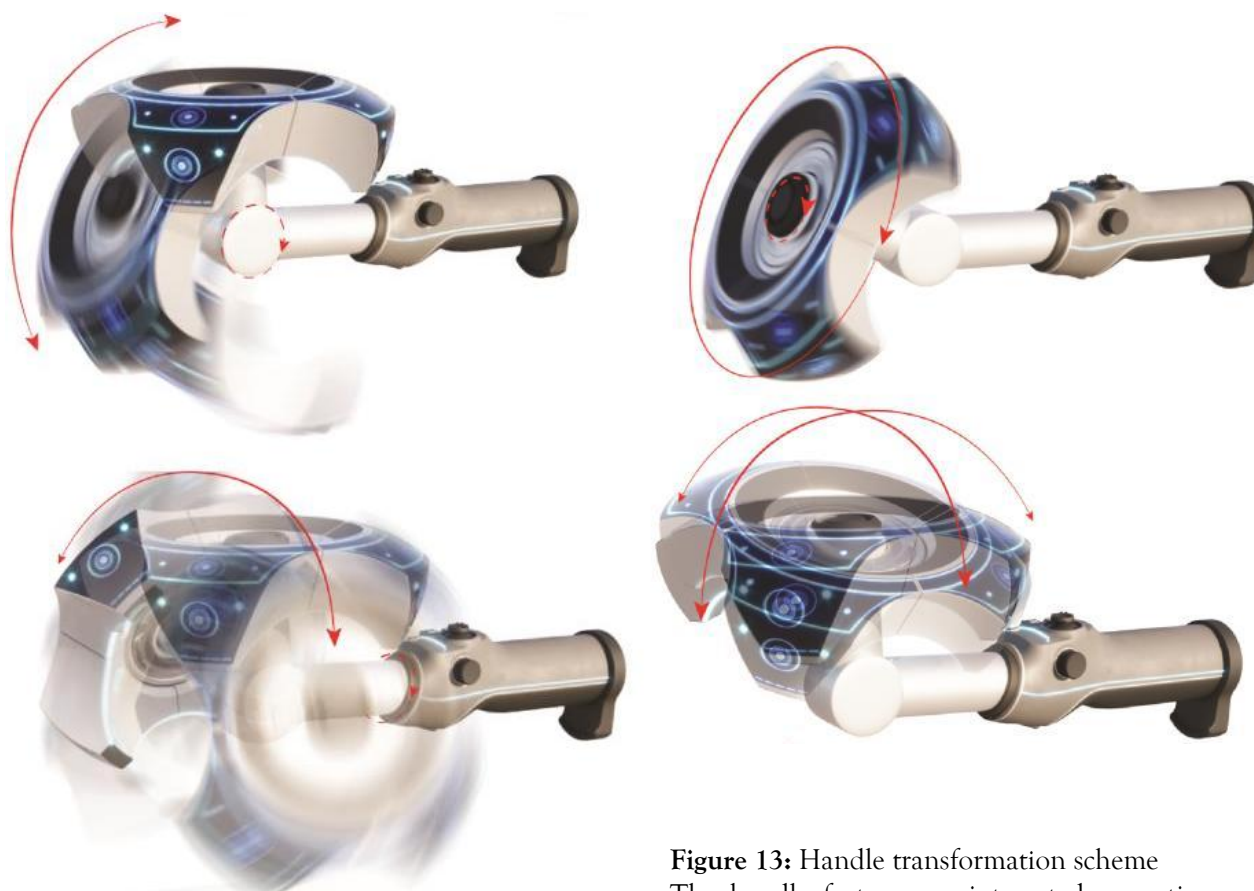

Figure 13: Handle transformation scheme

The handle features an integrated mounting mechanism compatible with the scanner-camera (Fig. 14). It includes precise mounting points, secure locking mechanisms, and allows for easy assembly and disassembly. Exploded diagram of the scanner (Fig. 15).



Figure 14: General structure and appearance of the handle

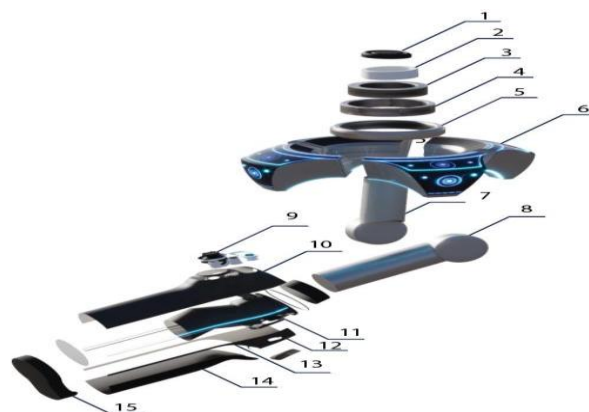

Figure 15: Exploded diagram: 1-frame, 2-axis 1, 3-axis 2, 4-axis 3, 5-coupler, 6-scanner, 7-movement arm 1, 8-movement arm 2, 9-control clamps, 10-body 1, 11-inner body, 12-decorative light, 13-body 2, 14-finger table part, 15-finger table part

3. CHARGING DEVICE

The modular scanner camera charger is an innovative technology designed to ensure efficient and uninterrupted charging of your device (Fig. 16). With its sleek, minimalist design, the charger offers a modern aesthetic that enhances the advanced features of the modular scanner camera. It is constructed from high-quality, durable materials.



Figure 16: Charging device

The surface of the charger has a matte finish that resists fingerprints and scratches. Its compact and lightweight design allows it to be placed easily on any desk, shelf, or workspace without occupying much space. The top of the charger includes a precision-engineered mount specifically designed to fit the base of the modular scanner camera. This mount is equipped with alignment guides and magnetic connectors that help position the camera accurately, ensuring a secure and stable connection every time (Fig. 17).

This magnetic docking system simplifies the charging process by eliminating the need to deal with cables, offering a straightforward and intuitive experience. Inside, the charger features advanced smart charging technology that communicates with the camera to deliver optimal power. It automatically adjusts the charging speed based on the camera's battery status, ensuring safe and efficient charging.

The charger features protection against overcharging, short circuits, and temperature fluctuations. It has a series of discreet LED indicators on the front panel that provide real-time feedback on the charging status. These LEDs glow softly to indicate when power is connected, during active charging, and when the device is fully charged. The gentle lighting is designed to be unobtrusive, allowing you to monitor the charging process without distraction.

The charger features a universal power input, allowing it to work with a variety of voltage levels and making it suitable for use in different regions around the world. It includes a detachable power cable that can be swapped out for different plug types as needed, enhancing its versatility and convenience for international travel or various settings (2).

In conclusion, the modular scanner camera charger serves not only as a functional accessory but also as a thoughtfully designed piece of technology that enhances the overall user experience through its thoughtful design, efficiency, and intelligent features.

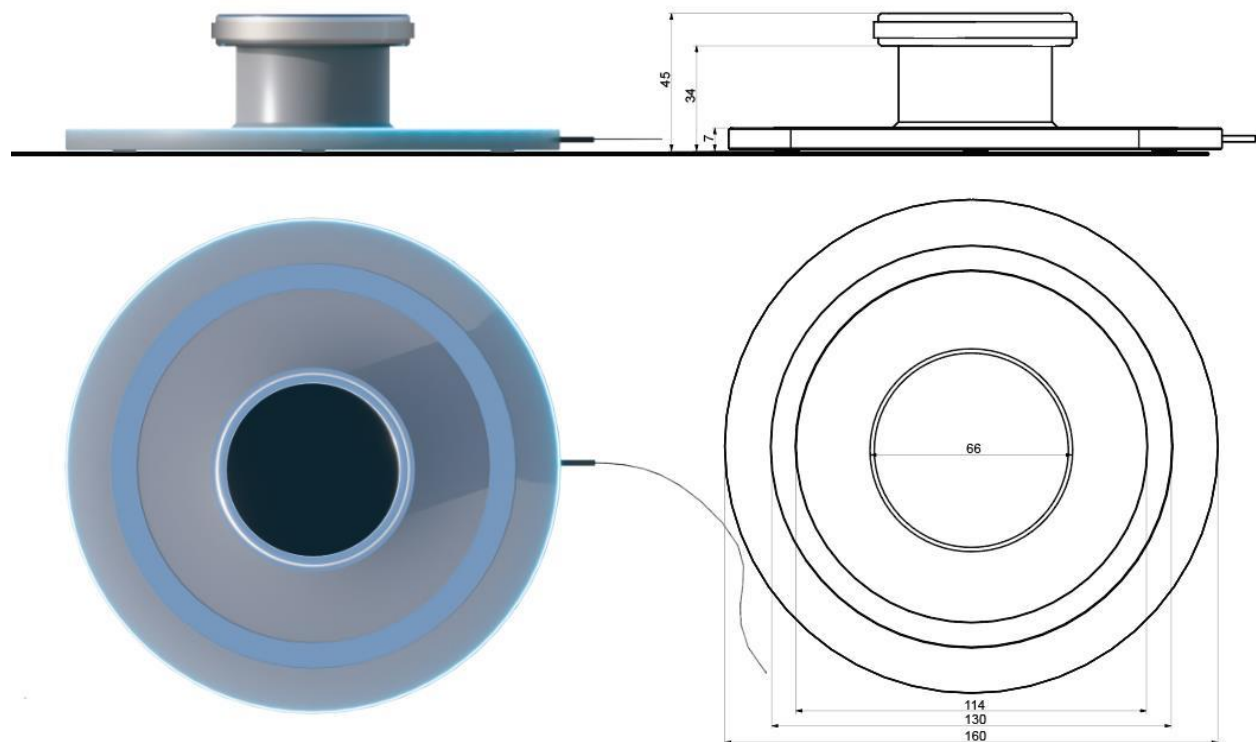

Figure 17: Projections and dimensions of the charging device

4. TRIPOD

The tripod will be positioned in the center of the interior to ensure the scanner operates effectively. Made from high-quality aluminum alloy, the tripod strikes the perfect balance between strength and lightweight design. The legs are not only robust but also light, providing excellent durability and mobility. Each leg features a matte anodized coating that enhances its resistance to scratches and corrosion, keeping it in optimal condition even after extensive use. With its three-legged structure, the tripod offers maximum stability on various surfaces.

Each leg is designed with adjustable telescopic sections that can be set independently, enabling customized height and angle configurations. The legs also include quick-lock mechanisms, allowing for easy and safe extension and retraction with a simple movement. This ensures a stable platform for the modular scanner camera in just seconds.

The top of the tripod is equipped with a specially designed mounting plate that fits the circular hole of the modular scanner. This section includes a quick-release mechanism, allowing you to easily attach and detach the scanner. Additionally, the device features a locking system that keeps the camera securely in place during use. It enables 360° rotation and offers a wide range of tilt angles, providing you with the flexibility to position the scanner camera precisely as needed.

The tripod head features adjustable knobs that enable precise micro-adjustments, ensuring perfect alignment for each scan. The legs are fitted with high-quality rubber feet that provide a secure grip on various surfaces, preventing slipping while allowing for easy positioning. Additionally, the tripod includes an extendable center column that can be adjusted vertically to achieve the desired height.

The legs of the tripod fold neatly for compact storage, allowing the entire unit to be easily transported. The tripod is not merely an accessory; it is an essential tool that enhances the functionality and versatility of the modular scanner camera.

Boasting sturdy construction, flexible adjustment options, and a user-friendly design, this tripod ensures accurate and stable scans in any environment.

5. VR/AR GLASSES

The project will utilize Apple Vision Pro VR glasses, a state-of-the-art virtual reality device designed for real-time simulation and alteration. When paired with an advanced scanning system, it enables users to

immerse themselves in indoor and outdoor environments with exceptional realism and accuracy. Merging Apple's renowned design aesthetics with the latest technology, Vision Pro glasses serve as the ideal tool for both professionals and enthusiasts. Below is a description of the VR/AR glasses.

6. UAV

For interior scanning, we used a handle and tripod, but for exterior modeling, UAV (Unmanned Aerial Vehicle) equipment is necessary. An advanced tracking system will be designed as a crucial component to enable the scanner to operate effectively outdoors. This robust system guarantees accurate positioning, stability, and high-quality data collection, even in challenging outdoor conditions.

The UAV integrates smoothly with your scanning equipment, allowing for precise and detailed imaging of expansive outdoor environments (see Figure 18). This UAV will be a key component of the system, delivering the accuracy, stability, and adaptability needed for high-quality outdoor scanning. With its advanced features and design, it ensures reliable and accurate data collection in a variety of outdoor settings, making it an essential tool for professionals across multiple fields.

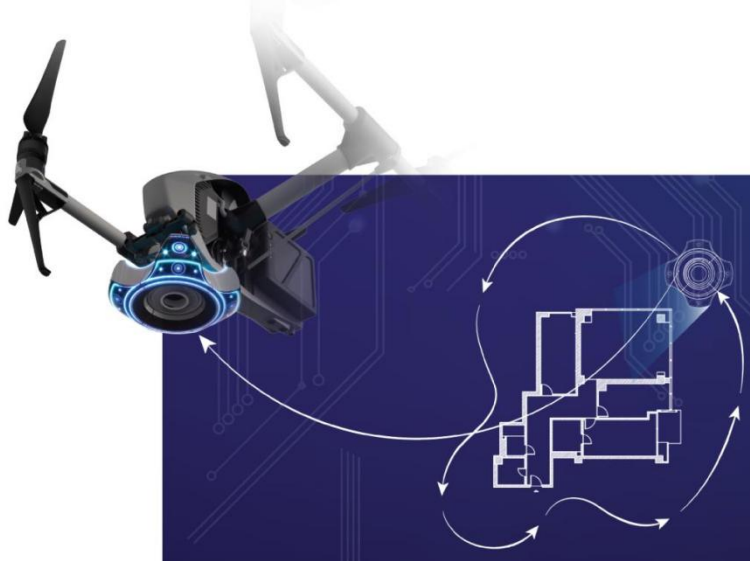

Figure 18: UAV

7. CONTROL PANEL

ControlPanel Pro is an advanced interface designed to effectively manage the scanner and VR headset during external scanning operations. It features intuitive controls, advanced functionality, and strong connectivity to ensure precise and efficient control over both scanning and virtual reality experiences.



Figure 19: Control panel

Thus, the equipment will have the following functions:

- Scanning the area or object under consideration
- Baseline data collection
- Data analysis and design concept development
- Creation of a three-dimensional model

- Provision of standardized drawings based on the model
- Generation of visual images based on the generated data
- Process organization and regulation with a VR/AR system
- Design presentation with a VR/AR system or alternative option.

The design proposal is centered around artificial intelligence and aims to create similar devices using generative programs. By addressing key market needs and leveraging current technological trends, this project is set to become an essential tool for professionals looking to enhance their workflows and achieve outstanding results.

With user-centered design, ease of use, and the potential for future improvements, devices are set to remain in demand and valuable in an evolving technological «landscape» (4).

CONCLUSION

The objective of the investigation was to elucidate the intersection between design methodology and artificial intelligence, culminating in a project that aims to transform the manner in which spatial data is acquired, rendered, and manipulated. The resultant devices constitute a comprehensive system designed to enhance accuracy, efficiency, and innovation across various domains, including architecture, design, real estate, and virtual environments. The primary objective of this suite of equipment is to provide professionals with advanced instrumentation for generating and visualizing spatial environments with unprecedented precision. Through the integration of sophisticated scanning technology and immersive VR/AR capabilities, the aim is to streamline the process of environmental scanning and three-dimensional design development, thereby enhancing accessibility and efficiency. This system is engineered to facilitate accurate data acquisition, intuitive interaction with analogous models, and seamless project progression from conceptualization to completion, including remote operations. Research has demonstrated that conventional methodologies for spatial data acquisition can be time-intensive and susceptible to inaccuracies, whereas the modular scanner-camera presents an expeditious, precise, and user-friendly solution for high-resolution scans of interiors and objects. The integration of data collection with design development can pose challenges, necessitating multiple tools and platforms. The proposed 3D design development platform consolidates all requisite tools into a single system, thereby ensuring a seamless workflow from scanning to final design implementation.

The integration of VR/AR technology demonstrably alters the manner in which users interact with spatial data. This technology facilitates a more intuitive comprehension of spaces and structures, which proves particularly advantageous for design reviews, client presentations, and collaborative planning. A salient feature of the system is its architecture, which ensures harmonious operation among the various technologies, thereby enhancing workflow efficiency. By addressing key challenges and offering innovative solutions, these devices enhance accuracy, efficiency, and user experience.

Whether for professional or creative purposes, the project allows users to achieve their goals with increased precision and ease, ushering in a new era of spatial data management and project development. To effectively explore the intersection of artificial intelligence and design, it is essential to study both fields, focusing on their unique characteristics, benefits, and challenges. This comprehensive examination helps to clarify the issues each discipline faces and reveals how they can complement one another. By realistically assessing the challenges of the design process and recognizing the vast opportunities offered by artificial intelligence services, effective collaboration can be achieved. Integrating AI technologies into the design process allows designers to utilize advanced tools and techniques that streamline workflows, automate repetitive tasks, and enhance design outcomes.

Tools powered by artificial intelligence can assist designers in generating ideas, exploring design alternatives, and making informed decisions, ultimately enhancing their creativity and productivity.

ABBREVIATION

NATO - The North Atlantic Treaty Organization

ACKNOWLEDGEMENT

We would like to thank National University of Architecture and Construction of Armenia for support.

FUNDING

The research and other costs are covered by the National University of Architecture and Construction of Armenia

CONFLICT OF INTEREST

The authors declare no conflict of interest.

AUTHORS' CONTRIBUTIONS

The author's contributions to the research article are as follows: study framework, Data collection, conception, visualization, methodology, draft manuscript preparation, Data analysis and Results.

ETHICS APPROVAL

Not applicable.

REFERENCES

1. Francesca Tosia, Alessandra Rinaldia, Ergonomics in Design: Medical Devices for Home care, Proceedings 19th Triennial Congress of the IEA, Melbourne 9-14 August 2015 <https://www.researchgate.net/publication/292963919>
2. Zeng, D. (2013). From Computational Thinking to AI Thinking [A letter from the editor]. IEEE Intelligent Systems, 28(6), 2-4. [<https://doi.org/10.1109/MIS.2013.141>]
3. Lasky, D., & Yoon, S. A. (2011). Making Space for the Act of Making: Creativity in the Engineering Design Classroom. Science Educator, 20(1), 34-43.
4. Long, D., & Magerko, B. (2020). What is AI Literacy? Competencies and Design Considerations. Proceedings of the 2020 CHI Conference on Human Factors in Computing Systems, 1-16. [<https://doi.org/10.1145/3313831.3376727>]