

AI-Based Hybrid Power Generation For Grid-Integrated PV And Wind Systems With Improved PCC Voltage And Power Factor

Srikanth D¹, G Durga Sukumar², Polamraju V. S. Sobhan³

¹Department of EEE, VFSTR, Vadlamudi, Guntur, Andhra Pradesh, India

²Department of EEE, Vignan Institute of Technology and Science, Telangana, India

³Department of EEE, VFSTR, Vadlamudi, Guntur, Andhra Pradesh, India

skecddata@gmail.com

ABSTRACT: In response with growing demands for electrical energy and the imperative for sustainability, this paper introduces a three-phase Solar-Wind hybrid system for efficient grid integration. Building upon previous research in solar and wind power, our paper addresses the intermittent nature of these sources by proposing a synergistic approach. The integration of solar and wind technologies aims to enhance overall system reliability and contribute to a more robust and environmentally friendly energy grid. By combining solar photovoltaic and wind power, the system optimizes performance at the grid connection. The integration uses MPPT techniques to enhance power output in varying weather. An ANN controller is developed for precise power point tracking of the photovoltaic array. This controller maintains stable grid voltage and unity power factor using Vector Control in a multilevel inverter. Simulation in MATLAB/SIMULINK validates the capacity of the system to optimize power utilization and stabilize the grid under changing conditions. In summary, the paper proposes a method to enhance Solar-Wind hybrid performance using MPPT and ANN control for accurate voltage regulation, resulting in significant improvements.

Keywords: Solar array, Wind energy, PV, MPPT, PI controller, ANN

1. INTRODUCTION

In light of the escalating global demand for ecofriendly energy solutions, the exploration of the renewable alternatives, viz., wind and photovoltaic (PV) power, has become paramount. However, existing literature and technologies exhibit certain gaps that necessitate further investigation. Notably, the reliance of solar and wind power on elements like sunlight and wind speed poses challenges to their reliability. The emerging trend of combining PV and wind into hybrids holds promise, but there remains a need for advancements in modeling, control systems, inverters, and sliding mode controls [1-4].

The existing literature highlights the common use of the Induction Generator with Dual Feed (DFIG) for wind energy extraction because of its simplicity and effectiveness. Despite this, there is still a gap in the comprehensive integration of a 1MW solar station and a 9MW wind facility through an AC-bus to enhance overall system performance. This research is motivated by the need to bridge these gaps, offering a more integrated and robust approach. Furthermore, while Peak Power drawing (MPPT) is acknowledged as crucial for enhanced maximum power generation in changing conditions, there is a need for a more detailed exploration of its application to both solar and wind sources within a hybrid system. This paper seeks to address these gaps by implementing MPPT for both sources, thereby maximizing power generation while maintaining a unity power factor and ensuring grid stability [2-3]. By delineating these specific research gaps, this paper not only aims to contribute to the academic understanding of PV/wind hybrid systems but also offers practical insights that can inform advancements in renewable energy technologies, addressing the pressing concerns of intermittency and power reliability. In this paper, we introduce a hybrid power system which is grid-connected that seamlessly integrates photovoltaic (PV) and wind assets, elucidated through a comprehensive Matlab/Simulink model. Both Proportional-Integral (PI) and ANN controllers effectively regulate the smooth DC link voltage of the Inverter (VSI). Simulation results underscore the superior performance of the ANN controller compared to the PI controller, particularly evident in improving the step response and settling time of the DC-link voltage (V_{dc}) [6-8]. The control framework ensures a unity power factor and facilitates reactive power injection, thereby guaranteeing the stability of the PCC bus voltage irrespective of external conditions or fluctuations in active power [9-10]. The proposed control approach consistently upholds the stability, reliability and performance of the hybrid system. Through the presentation of this advanced hybrid model and control strategy, this research not only addresses existing gaps in PV/wind hybrid systems but also contributes valuable insights for the enhancement of grid-connected renewable energy solutions[6].

In summary, this paper is structured to comprehensively address the optimal integration of power generation from photovoltaic (PV) and wind sources. Section II delves into the overarching theme of optimal integration for power generation from both PV and wind sources. Subsequently, Section III provides a systemic analysis of the photovoltaic power generation system, offering insights into its design and functionality. In Section IV, the focus shifts to the wind-to-power conversion system, exploring its components and operational considerations. Moving forward, Section V presents the Matlab simulation results, showcasing the accomplishments and efficiency of the integrated PV and wind power generation system. Finally, Section VI encapsulates the key findings and conclusions, summarizing the implications and potential avenues in the area of renewable energy integration for further advancements.

2. OPTIMAL POWER BLEND PV AND WIND INTEGRATION ANALYSIS

The hybrid PV/wind device combines a 100 kW solar station and a 9MW wind facility through a primary bus for better overall performance [7]. Solar modules in parallel use a boost converter and consolidated inverter. Incremental conductance MPPT extracts optimal PV energy under variable sunlight. The wind side has a DFIG with a huge wind turbine, integrating converters for voltage control and energy extraction using a power-based modified MPPT, it captures peak wind electricity, the hybrid device feeds the grid through a short 30kms line and a 25KV/120 KV (Y/ Δ) connected transformer[8][9] This integration maximizes resources, enhances device performance, and provides sustainable energy throughout diverse climate[10-13].

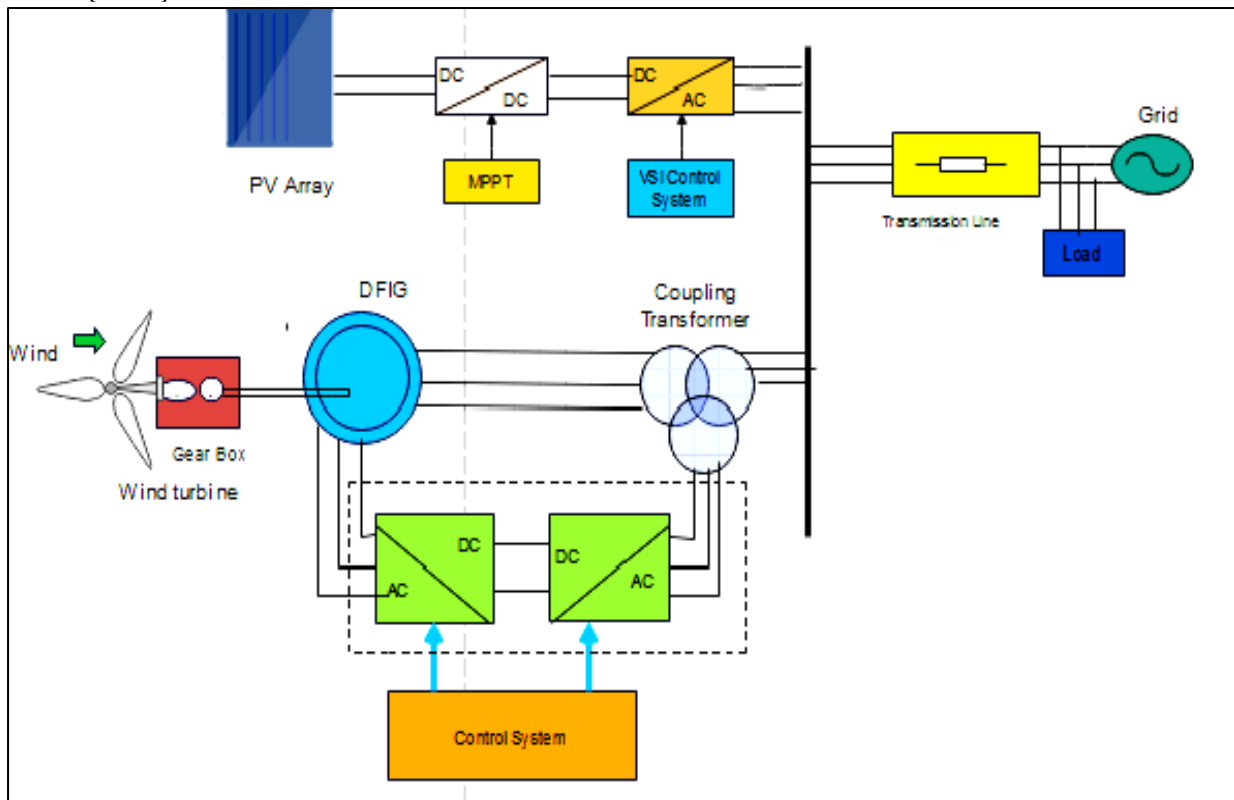

Figure 1 Renewables Integration Designing Solar-Wind Systems

3. PHOTOVOLTAIC POWER GENERATION SYSTEMIC ANALYSIS

The PV conversion device significantly improves solar energy generation via efficient modeling and tuning of photovoltaic arrays. This is so arranged to ensure cost-effectiveness, performance, and stable DC-link voltage. Shockley diode modeling replicates PV behavior for environmental simulations [12]. Incremental conductance MPPT tracks maximum power point, while the DC/AC inverter controller manages energy flow. Accurate modeling is critical for peak energy extraction. Figure 2 showcases array traits, adapting to solar modifications. MPPT and control techniques maximize PV energy, greatly boosting solar system efficiency [13].

3.1. Progressive Conductance peak power obtaining process

The Progressive Conductance MPPT algorithm is instrumental in optimizing the performance of PV systems [14]. It continuously adjusts the panel's voltage and current to ensure optimal operation at the peak power point (MPP), adapting to changes in temperature and irradiance [15]. By assessing the ratio

of power to voltage change, the progressive conductance MPPT algorithm determines the MPP shift direction. This adaptive process aligns the panel's conductance with power changes, gradually fine-tuning the voltage towards the MPP. Distinguishing itself from other MPPT methods, the progressive conductance technique excels, especially in rapidly changing conditions, enabling efficient and swift MPP tracking for optimized energy generation. Its efficacy and cost-effectiveness have solidified the progressive conductance MPPT as a favored choice in PV systems, significantly enhancing panel efficiency and overall power output [16].

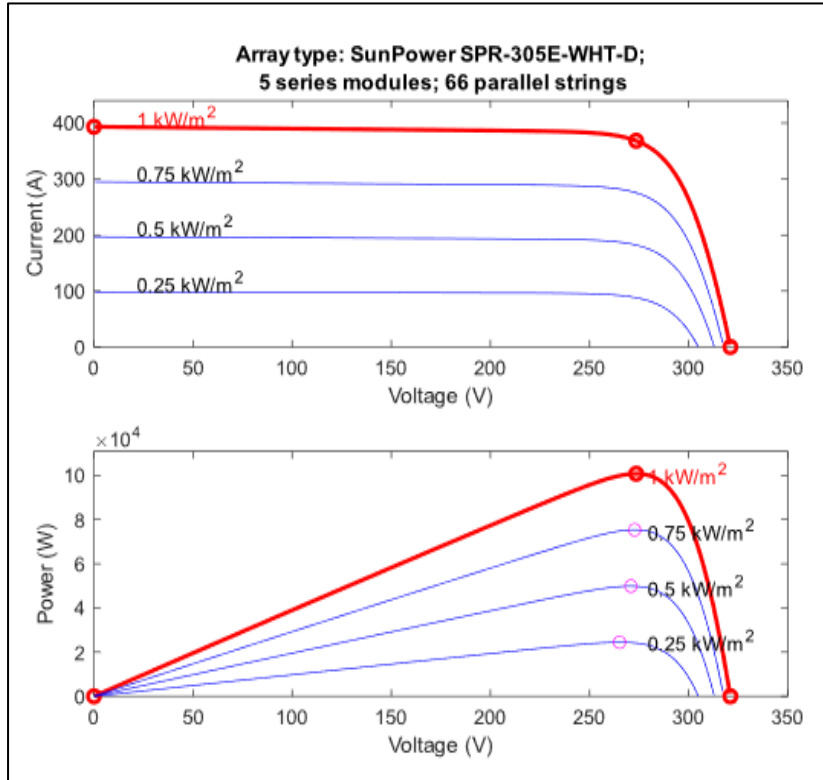

Figure 2. Performance Traits of PV Arrays across Changing Solar Irradiance

4. WIND-TO-POWER CONVERSION SYSTEM

The wind turbine model employs mathematical representations to illustrate its behavior in different scenarios. It envisions the turbine as an aerodynamic force transmitting torque to a DFIG [3]. Figure 3 visualization captures the power characteristic curve of the wind turbines, elucidating the clear association of the wind velocity and the mechanical power generated by the turbine of the wind farm [17].

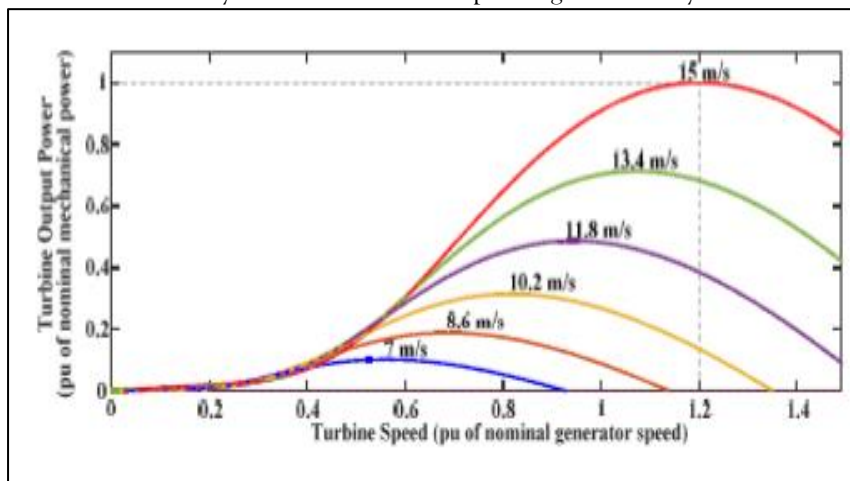

Figure 3. Wind Turbine Efficiency Profile.

Mathematically, the power usually mechanical produced by wind turbine, labeled as P_m , obtained as:

$$P_m = \left\{ \left(\frac{1}{2} \right) * \rho A (C_p) \lambda (V)^3 \right\} \tag{1}$$

Inside the supplied equation, the symbols correspond to the subsequent quantities: ρ indicates air density, A indicates rotor swept region, C_p represents energy coefficient, λ stands for tip speed ratio (TSR) and v configures wind velocity. The Speed ratio λ is given by:

$$\lambda = \omega_r \left(\frac{R}{v}\right) \quad (2)$$

Inside the given equation, the variables correspond to the following values: ω_r signifies the angular velocity of the rotor; R indicates the rotor radius. The wind turbine model consists of mechanical losses, such as friction and drag that are encapsulated torque T_{loss} , lessened from the input torque:

$$T_m = ((P_m - T_{loss})/\omega_r) \quad (3)$$

Here, T_m represents the wind turbines mechanical torque output.

The produced mechanical torque is inputted into the DFIG, where it undergoes conversion into electric power for seamless integration with the grid. The behavior of the DFIG can be appropriately represented the usage of principles from electric circuit idea. By using modeling the DFIG and the entire wind turbine system, it turns into feasible to employ control and optimization strategies for wind energy conversion systems. These models enable first-class-tuning of system performance and efficiency [18].

4.1. Enhanced Wind Power Generation through Modified MPPT

The improved MPPT method incorporates the measurement of power to precisely follow the best speed for a wind turbine, rendering wind speed measurements unnecessary [4]. This approach evaluates mechanical power to accurately pinpoint the ideal rotor rotation speed (ω_{ref}) that corresponds with the wind farm's highest power output. Through the utilization of mechanical power calculations, this strategy presents a practical means to optimize power generation without relying on wind speed information [5].

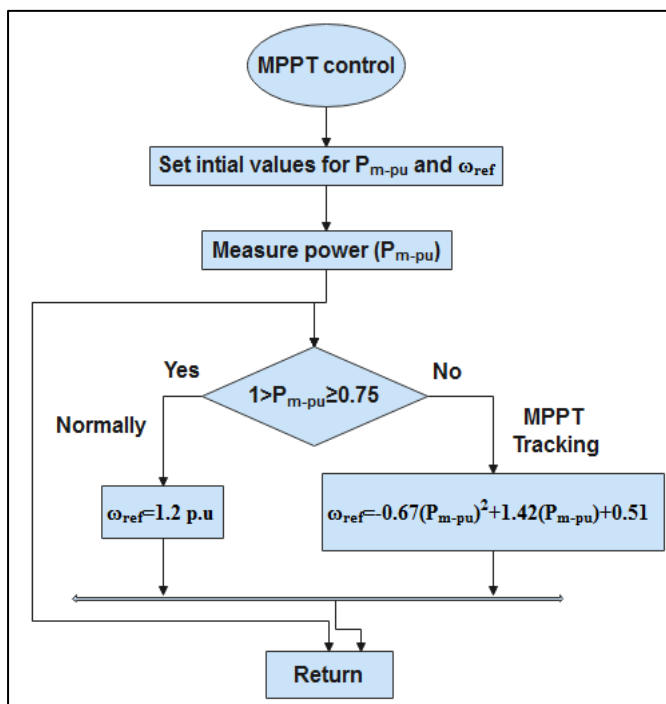

Figure 4. Improved MPPT Strategy Flowchart Incorporating Mechanical Power Analysis

The enhanced MPPT strategy's depiction is achievable through a flowchart. The sequence initiates by defining initial parameters: mechanical output power in per unit (P_{m-pu}) and the satisfactory angular velocity rotational speed (ω_{ref}). Following this, the actual mechanical energy is computed should the computed energy surpass 0.75p.u., the speed is customized to 1.2 p.u., in congruence with the 9 MW peak output. Conversely, if the energy stays below 0.75 p.u., the ideal speed is calculated with the use of the supplied equation. This process eliminates the need for wind speed measurements when evaluating the turbine's performance.

The tailored MPPT control method is designed to proficiently oversee and uphold the peak power generation of wind turbines, even within the presence of model inconsistencies or less precise wind speed sensors. Drawing upon the recorded mechanical electricity, this technique acts as a reliable indicator of the turbine's electricity technology, allowing precise calculation of the ideal rotor rotation speed by means of removing the requirement for wind velocity measurement, this adapted MPPT method simplifies the

control mechanism, decreasing susceptibility to errors therefore, it complements the performance and overall performance of the wind power conversion device.

5. RESULTS AND DISCUSSION

Through the utilization of the advised MPPT method and manage methods, the simulation effects underscore the efficiency of the advocated method in correctly tracking the peak energy point for photovoltaic (PV) stations and wind farms. Moreover, these manage strategies assure a regular voltage on the common coupling Point (PCC) with the grid. The hybrid device proposition achieves a upf and removes the injection of reactive energy, even if faced with fluctuations in active power due to environmental changes. These findings suggest the feasibility and accomplishment of the proposed method and manage methodologies in the context of the solar-wind hybrid device.

5.1. Solar Irradiance-Driven PV System Performance with PI Controller

Within this phase, we compare the effectiveness of the MPPT algorithm across a range of solar irradiation stages, extending from $1000\text{W}/\text{m}^2$ to a $250\text{W}/\text{m}^2$, as illustrated in figure 5(a).

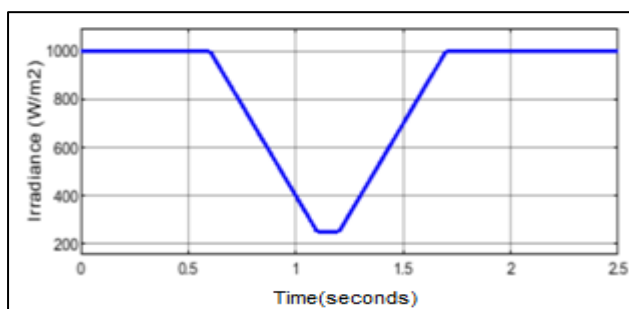

Figure 5(a) Solar Irradiance Variations

Figure 5(b) shows sequential changes in solar irradiance which effects the PV current (I_{pv}), main to a discount in the PV output current.

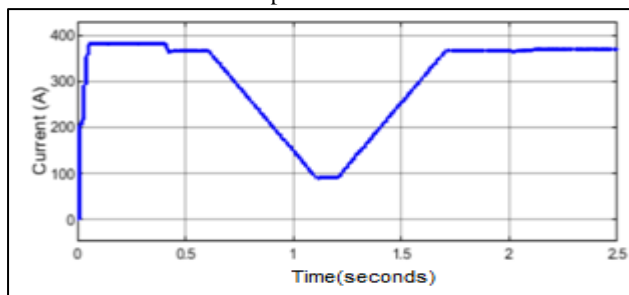

Figure 5(b) Changes in PV Array Current

Figure 5(c) shows the efficacy of the proposed MPPT controller to adapt the PV voltage (V_{pv}) in reaction to changing irradiance situations.

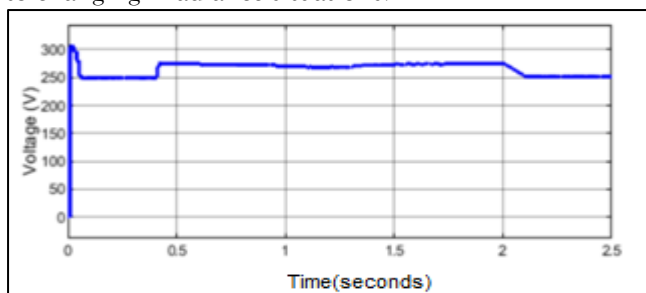

Figure 5(c) Voltage Variation in PV Array

Figure 5(d) shows the Active and Reactive Powers injected into the grid. It also shows that the reactive power injected is almost zero.

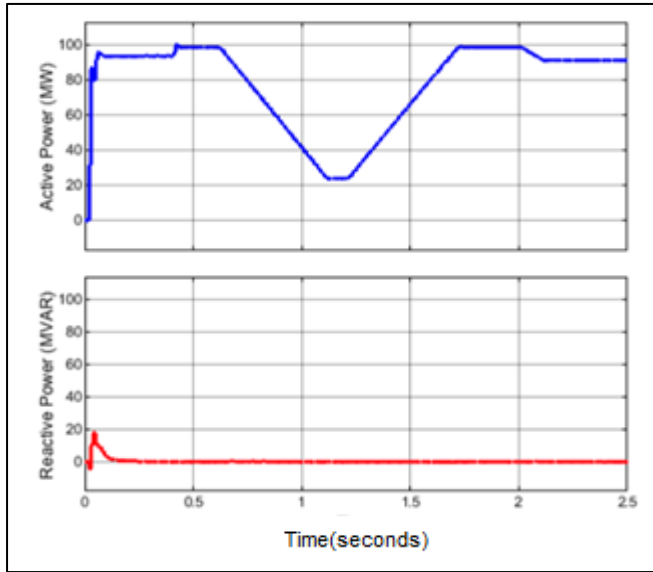

Figure 5(d) P & Q injected to Grid

Figure 5(e) shows the VSC Voltage and current waveforms of three Phase controlled by PI Controller.

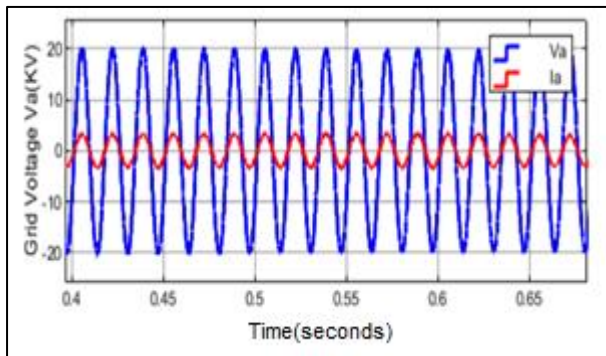

Figure 5(e). 3- Φ V-I Waveforms Controlled by PI

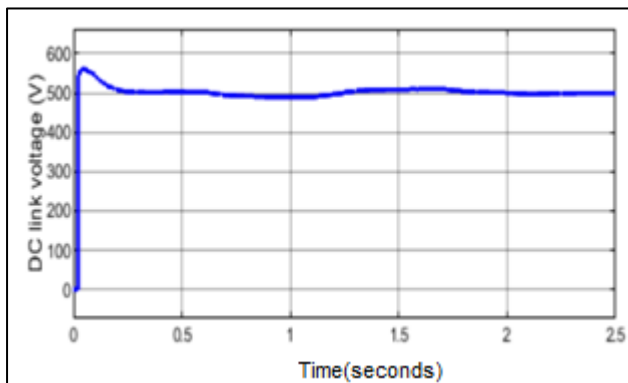

Figure 5(f). V_{dc} with PI

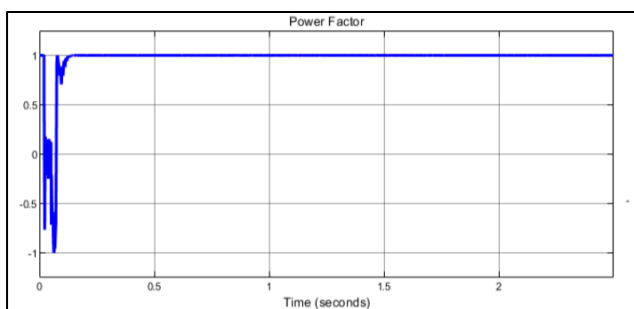

Figure 5(g). PFC of the Inverter using PI

Above simulation results shows the various effects for the PV system across various environmental conditions. Figure 5(a) demonstrates the MPPT algorithm performance for various irradiances from 1000 W/m² to 250 W/m². The impact of irradiance modifications on photovoltaic current (I_{pv}) is depicted in figure 5(b), where a decrease is evident similarly, figure 5(c) shows the modifications of photovoltaic voltage (V_{pv}) via the MPPT controller. The active and reactive electricity injection of the PV station is proven in figure 5(d), active electricity varies with irradiation modifications, while reactive strength remains constant at 0. Figure 5(e) is an evidence of Sinusoidal waveforms represent grid voltage and current. The evaluation among DC-bus voltage control by the PI controller is picturized in figure 5(f), indicating slightly enhanced settling with the PI controller in the end, figure 5(g) exhibits the inverter strength element as measured by the PI controller.

6. Performance Evaluation of PV using ANN Controller under Numerous environmental situations.

An ANN based controller Grid Integration Voltage and Power waveforms are obtained as shown in Figure (a).

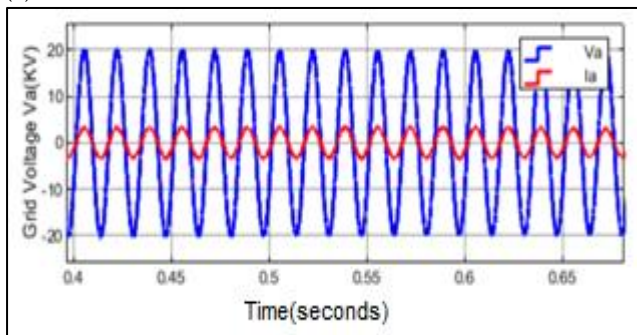

Figure 6(a). V-I Waveforms Utilizing ANN

The stabilization of V_{dc} with the ANN based controller is highlighted in Figure (b).

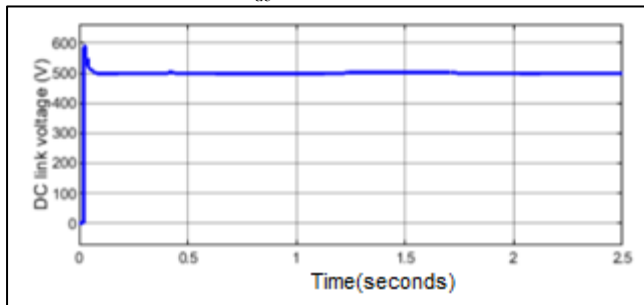

Figure 6(b). DC Link Voltage Management with ANN Controller

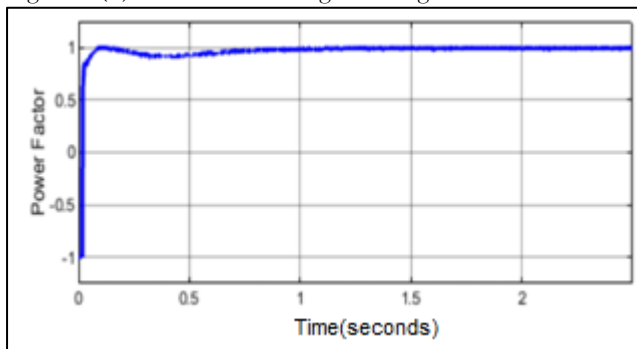

Figure 6(c). Inverter PF Control Utilizing ANN

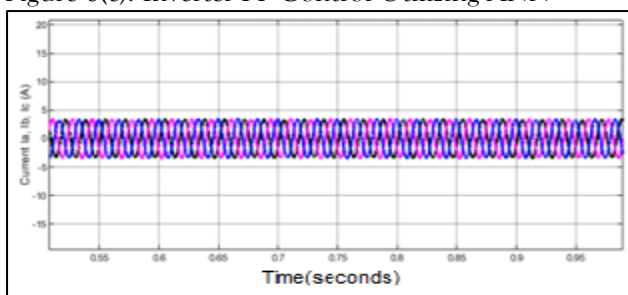

Figure 6(d). Injected PV Station Current

Power factor of the Inverter under varying solar irradiance conditions is showcased in Figures 6(c) and 6(d), providing a clear representation of the ANN controller's effectiveness in regulating the performance of the PV station.

7. Wind Farm Efficiency across Fluctuating Wind Speeds

In Figure 7(a), the dynamic reaction of the wind farm to fluctuating wind speeds is presented, illustrating the alterations in wind velocity. Remarkably, the GSC controllers consistently maintain the DC bus voltage, as demonstrated in Figure 7(b), throughout the range of wind speed changes.

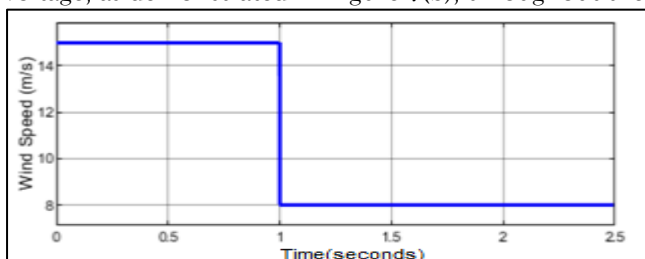

Figure 7(a). Wind Velocity Profile

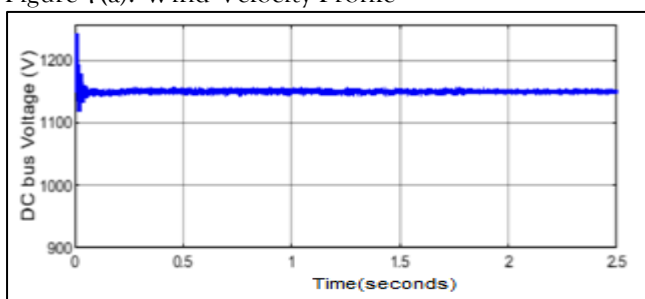

Figure 7(b). DC-Link Voltage(Vdc) of DFIG

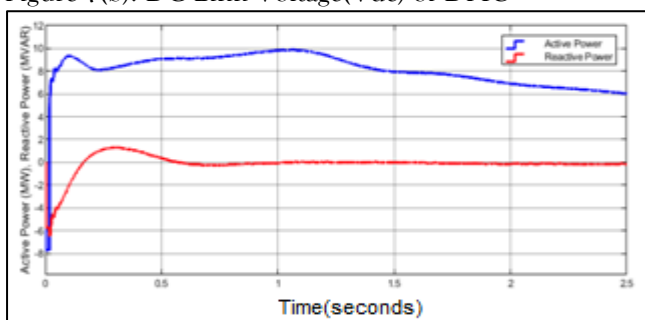

Figure 7(c). Injected P and Q from Wind Farm

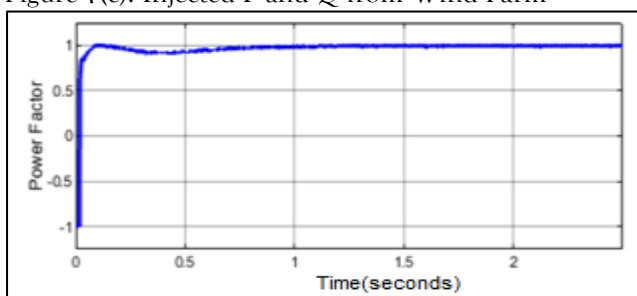

Figure 7(d). Inverter Power Factor

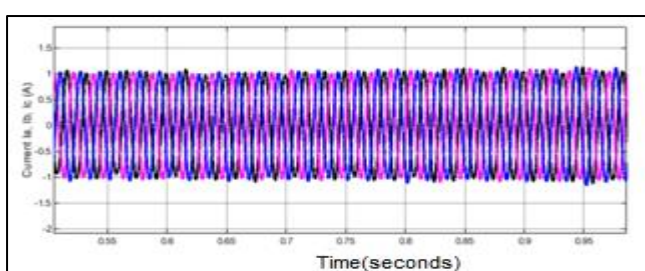

Figure 7(e). Wind Farm-Injected Current

Figure 7 illustrates the wind plant performance under numerous wind velocities. In Figure 7(a), changes in wind velocity are depicted, while Figure 7(b) underscores the consistent maintenance of the V_{dc} ensured by the effective GSC controllers. Modifications in injected active and reactive power during wind speed fluctuations are presented in Figure 7(c), with the MPPT control closely tracking the reference speed (ω_{ref}) to achieve high active and no reactive power injection, resulting in a upf as illustrated in Figure 7(d). Figure 7(e) showcases the injected waveforms of current, highlighting the adept management of active power injection by the RSC controller.

8. Comparison of different controllers with respect to DC-link voltage regulation and grid current THD% in a grid-connected hybrid PV-wind system context:

This section presents a comparative evaluation of PI, Fuzzy Logic (FLC), and Artificial Neural Network (ANN) controllers in maintaining DC-link voltage stability and minimizing grid current harmonic distortion in a grid-connected hybrid PV-Wind system.

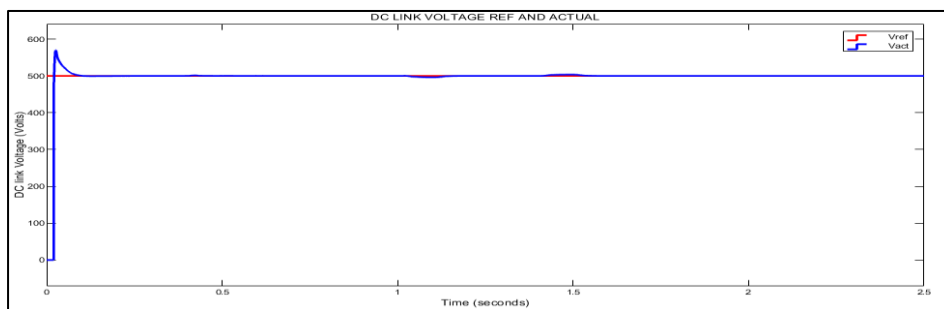

Figure 8(a). DC Link Voltage with PI Controller

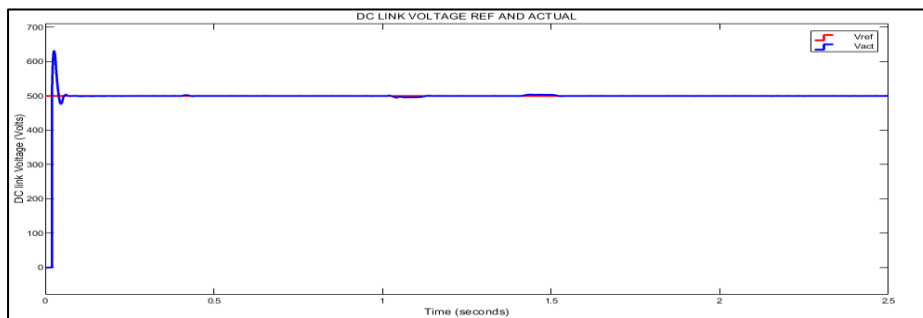

Figure 8(b). DC Link Voltage with FLC Controller

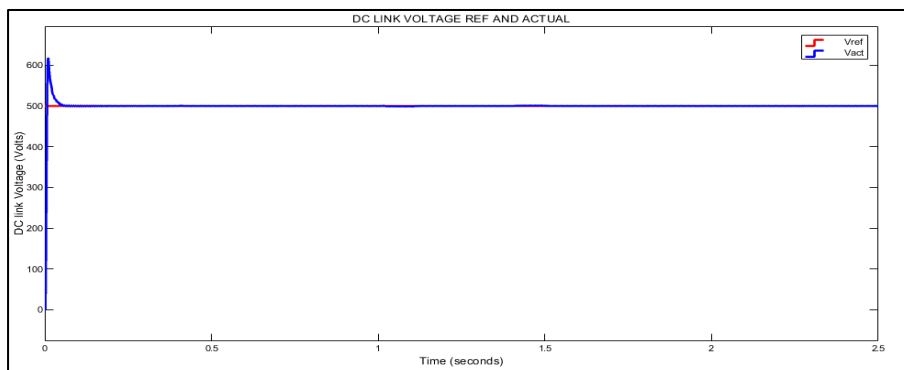

Figure 8(c). DC Link Voltage with ANN Controller

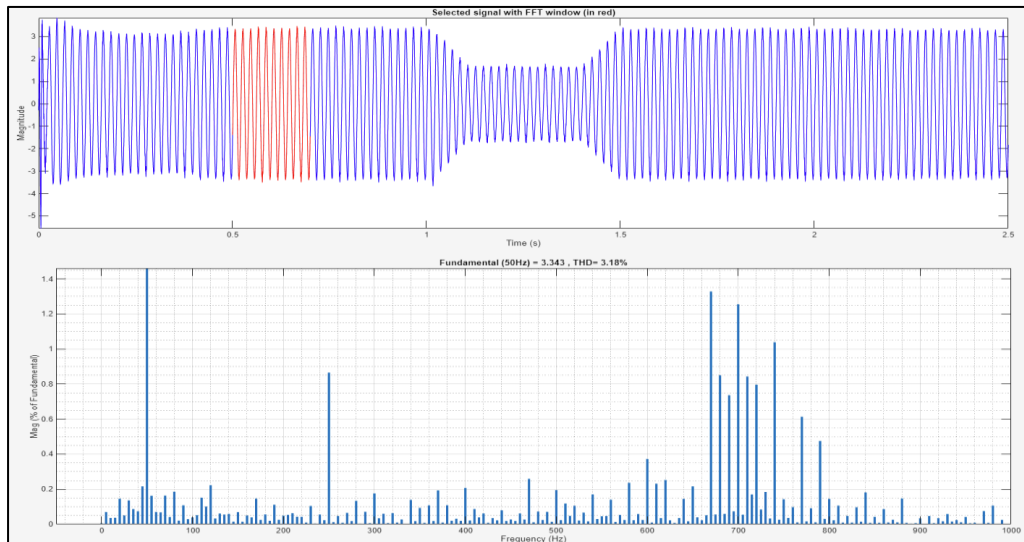

Figure 8(d). THD with PI Controller

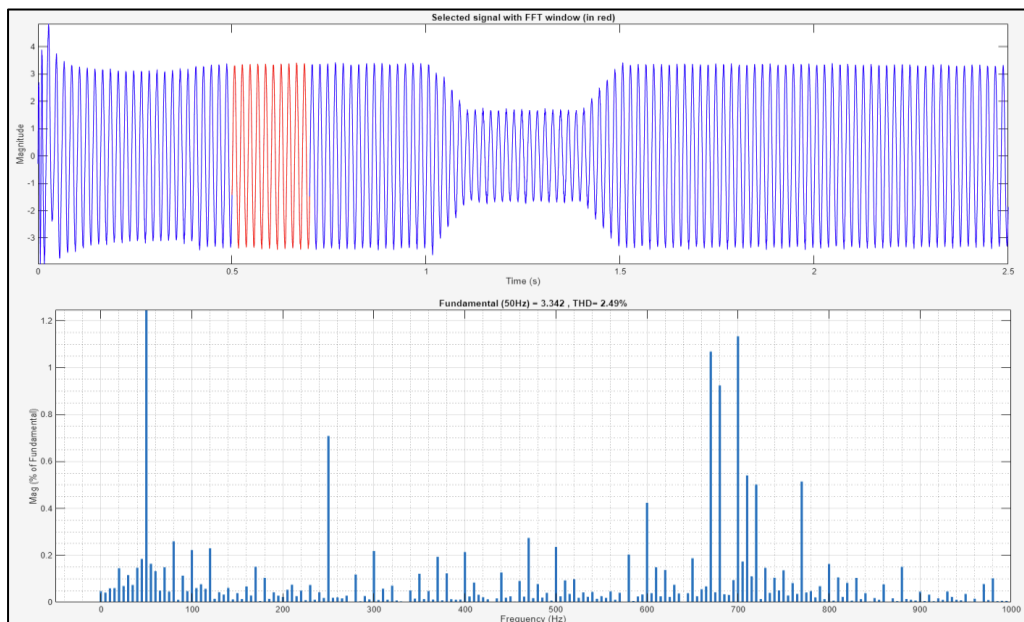

Figure 8(e). THD with FLC Controller

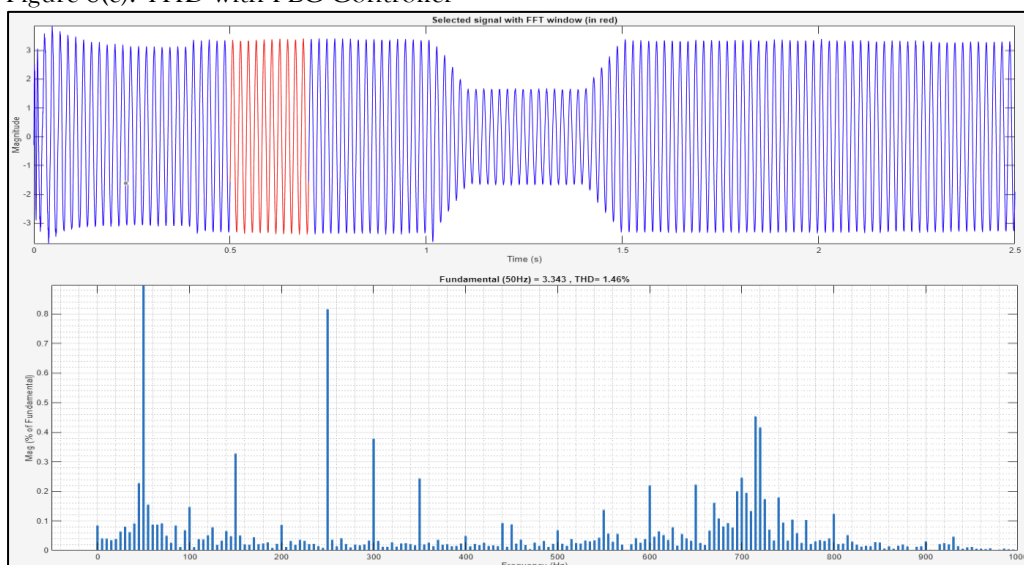

Figure 8(f). THD with PI Controller

The DC-link voltage is a critical parameter in hybrid systems to ensure proper power exchange between renewable sources and the grid. Figures 8(a)–8(f) illustrate the performance of each controller. From the figures, it is evident that:

- The **PI controller** exhibits a moderate overshoot and longer settling time.
- The **FLC** improves settling time and handles nonlinearity better.
- The **ANN controller** shows the best voltage regulation with minimal overshoot and fastest settling response, especially during transients caused by PV irradiance and wind speed variations.

TABLE I : Step Response Analysis of DC Link Voltage and Grid Current THD(%) Using Various Control Strategies

Step Info	PI	FLC	ANN
Rise Time	8.2790e-05	7.5707e-05	0.0036
Transient Time	0.00650	0.0515	0.0397
Settling Time	0.0650	0.0515	0.0397
Settling Min	483.1429	475.8806	456.553
Settling Max	570.3889	632.7029	618.7411
Overshoot	14.0789	26.5402	23.7266
Undershoot	0	0	0
Peak	570.386	632.7029	618.7411
Peak Time	0.0254	0.0257	0.0098
Current THD(%)	3.18	2.49	1.46

Table I presents the comparative step response characteristics of the DC-link voltage and the grid current Total Harmonic Distortion (THD%) using PI, Fuzzy Logic Controller (FLC), and Artificial Neural Network (ANN)-based control strategies in a grid-connected hybrid PV-wind system. The PI controller exhibits the shortest rise time (8.2790×10^{-5} s) and transient time (6.50 ms), but its performance is limited by a longer settling time (65 ms), moderate overshoot (14.07%), and the highest grid current THD of 3.18%, indicating poorer harmonic mitigation. The FLC slightly improves the settling time (51.5 ms) and reduces THD to 2.49%, but shows a higher overshoot (26.54%) and greater voltage deviation, which may affect converter stress and stability. In contrast, the ANN controller demonstrates the best dynamic response among the three, achieving the lowest settling time (39.7 ms), controlled overshoot (23.73%), and minimum THD of 1.46%. Although the ANN's rise time (3.6 ms) is higher due to smoother control transitions, it reaches the peak faster (9.8 ms) and maintains voltage within tighter bounds (456.55 V to 618.74 V), reflecting superior adaptation to system nonlinearities and transient disturbances. Overall, the ANN-based approach provides the most effective balance between voltage regulation and power quality enhancement, making it highly suitable for dynamic renewable energy environments.

9. CONCLUSION

This paper presented a comprehensive comparison of PI, Fuzzy Logic (FLC), and Artificial Neural Network (ANN) controllers for DC-link voltage regulation and grid current harmonic reduction in a grid-connected hybrid PV-wind energy system. The performance evaluation was based on key time-domain parameters such as rise time, settling time, overshoot, and peak response, along with frequency-domain analysis in terms of grid current THD (%). Results indicate that while the PI controller ensures fast initial response, it exhibits higher THD (3.18%) and longer settling time, making it less effective under dynamic operating conditions. The FLC improves THD to 2.49% and shows better voltage regulation but introduces higher overshoot and voltage instability. In contrast, the ANN controller outperforms both, achieving the lowest settling time (39.7 ms), controlled overshoot (23.72%), and significantly reduced THD (1.46%). These results confirm that ANN-based control offers superior dynamic performance and power quality, making it a more suitable choice for advanced grid-connected renewable energy applications, where adaptability and robust performance are critical under variable environmental conditions.

REFERENCES

- [1] S.B. Kjaer, J.K. Pedersen, and F. Blaabjerg, "A review of single-phase grid-connected inverters for photovoltaic modules," *IEEE Transactions on Industry Applications*, Vol. 41, No. 5, Sept. 2005, pp. 1292-1306. doi:10.1109/TIA.2005.853371.

- [2] Quincy Wang and Liuchen Chang, "An intelligent maximum power extraction algorithm for inverter-based variable speed wind turbine systems," *IEEE Transactions on Power Electronics*, Vol. 19, No. 5, Sept. 2004, pp.1242-1249. doi: 10.1109/TPEL.2004.833459.
- [3] R. Benadli and A. Sellami, "Sliding mode control of a photovoltaic-wind hybrid system," in 2014 International Conference on Electrical Sciences and Technologies in Maghreb (CISTEM), pp. 1-8, 2014. doi: 10.1109/CISTEM.2014.7077041.
- [4] M. Kumar, K. Sandhu, and A. Kumar, "Simulation analysis and THD measurements of integrated PV and wind as hybrid system connected to grid," in 2014 IEEE 6th India International Conference on Power Electronics (IICPE), pp. 1-6, 2014. doi: 10.1109/IICPE.2014.7115779.
- [5] T. R. Ayodele, A.-G. A. Jimoh, J. Munda, and J. Agee, "Dynamic Response of a Wind Farm Consisting of Doubly-Fed Induction Generators to Network Disturbance," in *Simulation and Modeling Methodologies, Technologies and Applications*, ed: Springer, pp. 131- 150, 2013. doi: 10.1007/s42452-020-2169-6.
- [6] S. D, G. D. Sukumar and P. V. S. Sobhan, "Effective Power Management of Grid-Connected PV System," 2023 World Conference on Communication & Computing (WCONF), RAIPUR, India, 2023, pp. 1-6, doi: 10.1109/WCONF58270.2023.10235098.
- [7] E. Koutroulis, K. Kalaitzakis, and N. C. Voulgaris, "Development of a microcontroller-based photovoltaic maximum power point tracking control system," *IEEE Transactions on Power Electronics*, Vol. 16, No. 1, Jan. 2001, pp. 46-54. doi: 10.1109/63.903988.
- [8] C.S. Brune, R. Spee, and A.K. Wallace, "Experimental evaluation of a variable-speed doubly-fed wind-power generation system," *IEEE Transactions on Industry Applications*, Vol. 30, No. 3, May 1994, pp.648-655. doi: 10.1109/IAS.1993.298967.
- [9] H. Laabidi and A. Mami, "Grid connected Wind-Photovoltaic hybrid system," in 2015 5th International Youth Conference on Energy (IYCE), pp. 1-8,2015. doi: 10.1109/IYCE.2015.7180770.
- [10] A. B. Oskouei, M.R.Banaei, and . Sabahi, "Hybrid PV/wind system with quinary asymmetric inverter without increasing DC-link number," *A in Shams Engineering Journal*, vol. 7, pp. 579-592, 2016. doi: <http://dx.doi.org/10.1016/j.asej.2015.06.008>.
- [11] A. Parida and D. Chatterjee, "Cogeneration topology for wind energy conversion system using doubly-fed induction generator," *IET Power Electronics*, vol.9, pp. 1406-1415, 2016. doi: 10.1049/iet-pel.2015.0581.
- [12] B. Singh, S. K. Aggarwal, and T. C. Kandpal, "Performance of wind energy conversion system using a doubly fed induction generator for maximum power point tracking," in *Industry Applications Society Annual Meeting (IAS)*, 2010 IEEE, 2010, pp. 1-7. doi: 10.1109/IAS.2010.5614738.
- [13] [A. Parida and D. Chatterjee, "Model-based loss minimisation scheme for wind solar hybrid generation system using (grid-connected) doubly fed induction generator," *IET Electric Power Applications*, vol. 10, pp. 548-559, 2016. doi: 10.1049/iet-epa.2015.0645.
- [14] K. Rajesh, A. Kulkarni, and T. Ananthapadmanabha, "Modeling and Simulation of Solar PV and DFIG Based Wind Hybrid System," *Procedia Technology*, vol. 21, pp. 667-675, 2015. doi: <https://doi.org/10.1016/j.protcy.2015.10.080>.
- [15] D. Sera, L. Mathe, T. Kerekes, S. V. Spataru, and R. Teodorescu, "On the perturb-and-observe and incremental conductance MPPT methods for PV systems," *IEEE journal of photovoltaics*, vol. 3, pp. 1070-1078, 2013. doi: 10.1109/JPHOTOV.2013.2261118.
- [16] M. Rama Krishna, K. Rakesh Tej Kumar & G. Durga Sukumar (2018) Antireflection nanocomposite coating on PV panel to improve power at maximum power point, *Energy Sources, Part A: Recovery, Utilization, and Environmental Effects*, 40:20, 2407-2414, DOI: 10.1080/15567036.2018.1496198.
- [17] M. Brenna, R. Faranda, and S. Leva, "Dynamic analysis of a new network topology for high power grid connected PV systems," in 2010 IEEE Power and Energy Society General Meeting, pp. 1-7, 2010. doi: 10.1109/PES.2010.5589768.
- [18] B. E. Strand, "Voltage Support in Distributed Generation by Power Electronics," *Master of Science in Energy and Environment*, pp. 1-87, June 2008.
- [19] A. Althobaiti, M. Armstrong, and M. Elgendy, "Current control of three phase grid-connected PV inverters using adaptive PR controller," in 2016 7th Renewable Energy Congress (IREC), International, pp. 1-6, 2016. doi: 10.1109/IREC.2016.7507628.
- [20] M. Zhou, G. Bao, and Y. Gong, "Maximum power point tracking strategy for direct driven PMSG," in 2011 Asia-Pacific Power and Energy Engineering Conference (APPEEC), pp. 1-4, 2011. doi: 10.5281/zenodo.1093099.
- [21] Ghada Boukettaya, Lotfi Krichen, A dynamic power management strategy of a grid connected hybrid generation system using wind, photovoltaic and Flywheel Energy Storage System in residential applications, *Energy*, Volume 71, 2014, Pages 148-159, ISSN 0360-5442, <https://doi.org/10.1016/j.energy.2014.04.039>.
- [22] Mehdi Dali, Jamel Belhadji, Xavier Roboam, Hybrid solar-wind system with battery storage operating in grid-connected and standalone mode: Control and energy management - Experimental investigation, *Energy*, Volume 35, Issue 6, 2010, Pages 2587-2595, ISSN 0360-5442, <https://doi.org/10.1016/j.energy.2010.03.005>.
- [23] Costanzo, G.T.; Kheir, J.; Guchuan Zhu; , "Peak-load shaving in smart homes via online scheduling," *Industrial Electronics (ISIE)*, 2011 IEEE International Symposium on , vol., no., pp.1347-1352, 27- 30 June 2011. DOI: 10.1109/ISIE.2011.5984354.
- [24] Ziming Zhu; Jie Tang; Lambotaran, S.; Woon Hau Chin; Zhong Fan; , "An integer linear programming based optimization for home demand-side management in smart grid" *Innovative Smart Grid Technologies (ISGT)*, 2012 IEEE PES , vol., no., p.1-5, 16-20 Jan. 2012. DOI: 10.1109/ISGT.2012.6175785.
- [25] Jidong Wang; Zhiqing Sun; Yue Zhou; Jiaqiang Dai; , "Optimal dispatching model of Smart Home Energy Management System," *Innovative Smart Grid Technologies - Asia (ISGT Asia)*, 2012 IEEE , vol., no., pp.1-5, 21-24 May 2012. DOI: 10.1109/ISGT-Asia.2012.6303266.
- [26] W. H. Allen, A. Rubaai and R. Chawla, "Fuzzy Neural Network- Based Health Monitoring for HVAC System Variable-Air-Volume Unit," in *IEEE Transactions on Industry Applications*, vol. 52, no. 3, pp. 2513-2524, May-June 2016. DOI: 10.1109/TIA.2015.2511160.

- [27] K. Mansiri, S. Sukchai and C. Sirisamphan wong, "Fuzzy Control Algorithm for Battery Storage and Demand Side Power Management for Economic Operation of the Smart Grid System at Naresuan University, Thailand," in *IEEE Access*, vol. 6, pp. 32440-32449, 2018. DOI: 10.1109/ACCESS.2018.2838581.
- [28] Sameh ZENNED, Housseem CHAOUALI and Abdelkader MAMI, "Fuzzy Logic Energy Management Strategy of a Hybrid Renewable Energy System Feeding a Typical Tunisian House" *International Journal of Advanced Computer Science and Applications (IJACSA)*, 8(12), 2017. <http://dx.doi.org/10.14569/IJACSA.2017.081226>.
- [29] Ibrahim NF, Alkuhayli A, Beroual A, Khaled U, Mahmoud MM. Enhancing the Functionality of a Grid-Connected Photovoltaic System in a Distant Egyptian Region Using an Optimized Dynamic Voltage Restorer: Application of Artificial Rabbits Optimization. *Sensors (Basel)*. 2023 Aug 13;23(16):7146. doi: 10.3390/s23167146. PMID: 37631683; PMCID: PMC10458465.
- [30] Patra, R., Chaudhary, P., & Shah, O. (2024). "Design and Development of ANFIS based Controller for Three Phase Grid Connected System". *International Journal of Robotics and Control Systems*, 4(1), 125-138. doi:<https://doi.org/10.31763/ijrcs.v4i1.1242>.
- [31] Linus A. Aloo laloo@jkuat.ac.ke · Peter K. Kihato · Stanley I. Kamau · Roy S. Orenge "Modeling and control of a photovoltaic-wind hybrid microgrid system using GA-ANFIS" *Heliyon*, A CRC Press Journal, Volume 9, Issue 4, e14678 April 2023. <https://doi.org/10.1016/j.heliyon.2023.e14678>.
- [32] Aziz, M. A., & Husnayain, F. (2024). Comparison Performance Analysis of PI and PI-ANFIS in VSC-HVDC Transmission Systems. *International Journal of Electrical, Computer, and Biomedical Engineering*, 2(3), 302–326. <https://doi.org/10.62146/ijecbe.v2i3.66>.
- [33] Nasim, Farhat, Shahida Khatoon, Ibraheem, Shabana Urooj, Mohammad Shahid, Asmaa Ali, and Nidal Nasser. 2025. "Hybrid ANFIS-PI-Based Optimization for Improved Power Conversion in DFIG Wind Turbine" *Sustainability* 17, no. 6: 2454. <https://doi.org/10.3390/su17062454>
- [34] N. Tashakor, M. Kılıçtaş, J. Fang and S. M. Goetz, "Switch-Clamped Modular Multilevel Converters With Sensorless Voltage Balancing Control," in *IEEE Transactions on Industrial Electronics*, vol. 68, no. 10, pp. 9586-9597, Oct. 2021, doi: 10.1109/TIE.2020.3028814.
- [35] Nima Khosravi, Hamid Reza Abdol mohammadi, "A hierarchical deep learning-based recurrent convolutional neural network for robust voltage and frequency operation management in microgrids", *Applied Soft Computing*, Volume 170, 2025, 112645, ISSN 1568-4946, <https://doi.org/10.1016/j.asoc.2024.112645>.
- [36] Nima Khosravi, "Enhancing operational efficiency through a control-based approach for hydrogen and battery energy storage systems integration in renewable energy networks", *Renewable Energy*, Volume 248, 2025, 123132, ISSN 0960-1481, <https://doi.org/10.1016/j.renene.2025.123132>.
- [37] Nima Khosravi, "Finite-Time control scheme for effective voltage and frequency regulation in networked microgrids", *International Journal of Electrical Power & Energy Systems*, Volume 165, 2025, 110481, ISSN 0142-0615, <https://doi.org/10.1016/j.ijepes.2025.110481>.
- [38] N. F. Ibrahim et al., "Operation of Grid-Connected PV System With ANN-Based MPPT and an Optimized LCL Filter Using GRG Algorithm for Enhanced Power Quality," in *IEEE Access*, vol. 11, pp. 106859-106876, 2023, doi: 10.1109/ACCESS.2023.3317980.